

ACCESSORIES CASEGOODS

PRICING EFFECTIVE JUNE 2, 2025



Indiana
FURNITURE

Being over a century old hasn't slowed us down! Sure, we are still the reliable, ethical company that was born in southern Indiana, steeped in quality, craftsmanship, and service. But have you seen our latest introductions? We are making a splash with design and challenging the concept of modern offices. Go ahead. Take a look. You know you want to.

Our Pledge to People + Our Planet.

We've been making wood furniture longer than just about anyone...and we want to be doing so for a long time to come. That's a large part of why we take a stewardship approach to our resources. We believe that environmental sustainability and business profits need not be mutually exclusive. They can and should exist side by side in a mutually beneficial relationship. And for more than a century, we've been showing how it's done.

We've proven our commitment to a sustainable future by supporting the standards and programs that protect our home planet and human health. Whether it's local sourcing, reducing contaminants, implementing wellness and safety programs, or diverting waste from landfills, social responsibility is a part of every decision we make at Indiana Furniture.

One of the surest ways to reduce our impact on the planet is to make and buy things that last. And this one's a natural for us. Our products are made with craftsmanship and attention to detail that are a part of our more than a century-long legacy in wood manufacturing. And our products are backed by our 12-year warranty, which facilitates maintenance, servicing and reassembly.

All of our product lines:

- Are manufactured and assembled in the USA,
- Meet or exceed Indoor Air quality standards*,
- Meet or exceed BIFMA level® Sustainability standards and certification*,
- Conform to the BIFMA Compliance standards*,
- Comply with TSCA Title VI (CARB) standards,
- and can contribute to U.S. Green Building's LEED Program.

To learn more, simply go to www.IndianaFurniture.com/resources.



Ease of Specification

Whether you're looking to specify your office spaces or simply to visualize them in the options and surface materials you are desiring, we make it easy. You can find the entire Indiana Furniture portfolio on the following third-party, space-planning platforms.



* Recently launched or new products may still be in testing; Cush Pillows is currently not BIFMA Compliant due to no available compliance test.

Accessories

Grommets



Power + Coordinating Accessories

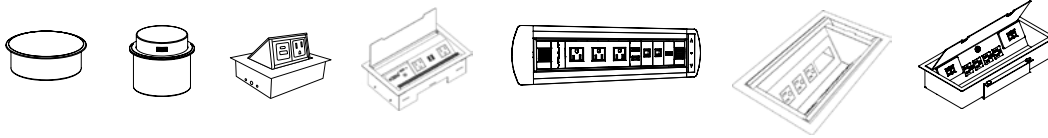

Power Units with Accessories

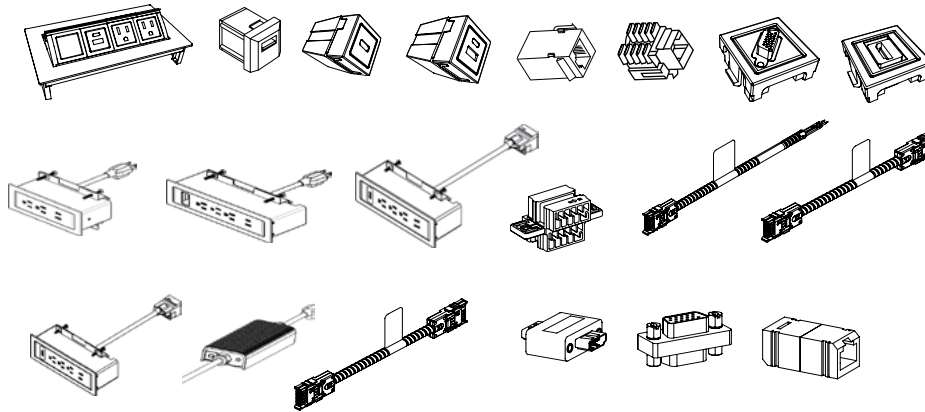

Wire Management

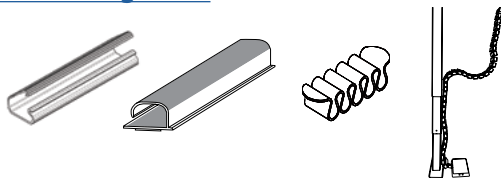

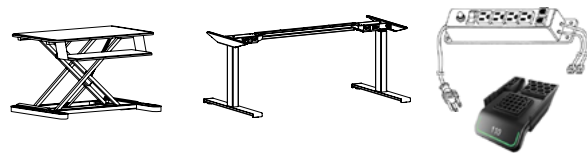

Height Adjust Components

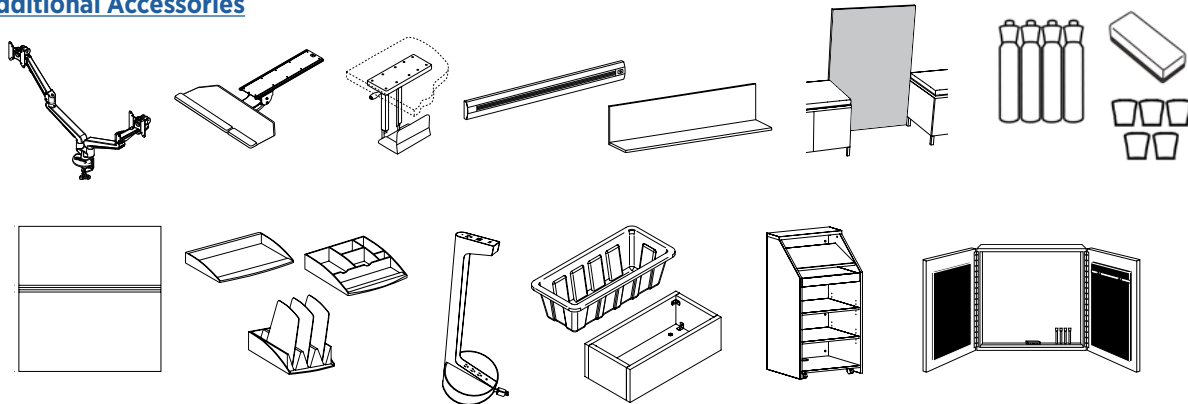

Additional Accessories

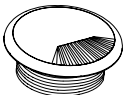
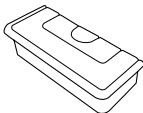

Item	Model No.		Width	Depth	Height	Ship Wt	Cubic Ft	List Price
ROUND GROMMET COVER FIELD INSTALLED	01-GRMTBK	Black	-	-	-	-	-	\$ 11
	01-GRMTSL	Silver						
 <p>OPEN MARKET ONLY (SILVER)</p>		Description <ul style="list-style-type: none"> • 60mm Round Grommet Cover • Field Installed 						
RECTANGULAR GROMMET	01-HUGRMTSL	Silver	-	-	-	1	.1	\$ 11
 <p>OPEN MARKET ONLY</p>		Description <ul style="list-style-type: none"> • For Use with Surface Mount Hatches Only • 70mm x 30mm Silver Rectangular Grommet with Cover • Field Installed 						
DOCK 950 WIRELESS CHARGER	01-DOCK950W	White	3 $\frac{3}{16}$	3 $\frac{3}{16}$	-	1	0.2	\$ 274
	01-DOCK950B	Black						
 <p>OPEN MARKET ONLY</p>		Description <ul style="list-style-type: none"> • For Use with Wireless Charging Enabled Devices • 5 Watts Maximum Output with a Direct Current of 5V 2A and 10 Watts Maximum with Quick Charge 2.0 • Mounts in 76mm Round Cut-Out • LED will Confirm Pairing with Device and Begin Wireless Charging 						
DOCK 150 WIRELESS AND USB CHARGER	01-DOCK150W	White	3	3	$\frac{3}{4}$	1	0.2	\$ 418
	01-DOCK150B	Black						
 <p>OPEN MARKET ONLY</p>		Description <ul style="list-style-type: none"> • For Use with Wireless Charging Enabled Devices and USB Charging Devices • 5 Watt Maximum Output with a Direct Current Input of 5V 6A (Wireless Fast Charge) • Mounts in 76mm Round Cut-Out • Pop-Up is $\frac{3}{4}$"H and Includes Three (3) USB Ports; One (1) 12 Watt Maximum with 2.4A (USB Fast Charge) and Two (2) 5 Watt with 1A (USB Standard Charge) • LED Light will Confirm Pairing with Device and Begin Wireless Charging • UL and cUL Certified 						

Item	Model No.		Width	Depth	Height	Ship Wt	Cubic Ft	List Price
POWER 440	01-DATA440A	Aluminum	5 $\frac{1}{16}$	4 $\frac{3}{8}$	—	5	0.2	\$ 996
	01-DATA440B	Black						

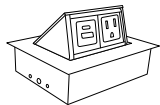
Description

- One (1) USB A+C and One (1) Power Outlets
- Soft Touch Hinged Lid
- 6' Power Cord

INTERACT POWER AND DATA	01-INTERACTG2A	Aluminum	9	5 $\frac{3}{8}$	2 $\frac{3}{4}$	5	0.2	\$ 920
	01-INTERACTG2B	Black						

Description

- Two (2) Power Outlets, **USB-A+C** Charging Ports, One (1) Data, One (1) Voice Telecom Plate Included
- Shown with Optional Telecom Plates; Sold Separately ([See Telecom Plates](#))
- Convenience Plug on Bottom
- 6' Power Cord
- UL and CSA Recognized

POWER AND DATA VAULT	01-CVAULTG2A	Silver	4 $\frac{1}{2}$	15 $\frac{7}{8}$	4 $\frac{1}{16}$	10	0.4	\$ 2008
----------------------	--------------	--------	-----------------	------------------	------------------	----	-----	---------

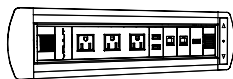

OPEN MARKET ONLY

Description

- Electric Drive Motor Rotates the Surface Technology 180° to the Proper Position
- Photo-Electronic Eye Prevents Rotation When Obstructed
- Two (2) Data Ports, Three (3) Power Outlets, One (1) HDMI and Two (2) 5V USB
- 6' Power Cord

OASIS MINI POWER & DATA	01-OASISMA	Aluminum	15	9	4 $\frac{15}{16}$	7	0.7	\$ 3296
	01-OASISMB	Black						

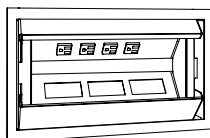

Top View

Description

- Includes Four (4) Power Outlets, Two (2) Data Ports, and One (1) Voice Telecom Plate
- Soft Touch Hinged Lid
- 9' Cord with Nema Plug; Fits 15A/120V AC Receptacles
- UL Listed
- Opening for One (1) Additional Telecom Plate; Sold Separately ([See Telecom Plates](#))

Item	Model No.		Width	Depth	Height	Ship Wt	Cubic Ft	List Price
POWER CENTER	01-INTRFC1A	Aluminum	14 ¼	6 ¾	3 ¾	11	0.3	\$ 2132
	01-INTRFC1B	Black						

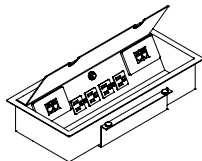

Description

- Four (4) Power Receptacles in Two (2) 15 Amp Duplexes
- One (1) 15 Amp Circuit Breaker
- One (1) Voice Port and Three (3) Data Ports
- One (1) Convenience Plug on Bottom
- 6' Foot Cord
- UL Listed/CSA Certified

NOTE: To order voice/data modules for your specific requirements contact the local computer or telecommunications installation service in your area.

DATA PORT 4	01-DPORT4A	Aluminum	8	4	—	7	0.2	\$ 1129
	01-DPORT4B	Black						

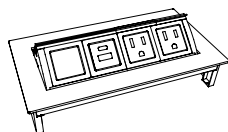

Description

- Includes: Two (2) Power Outlets, One (1) USB A+C, One (1) Open Port, 10' Power Cord, and Voice/Data Adapter Kit to Accept Couplers and Jacks When Required
- Retracts into Work Surface to Regain Productive Space; One-Touch Access to Power and Data
- Optional Telecom Port Components, See Compatible Units Below and On Next Page
- Water-Proof Simplex (Outlets)
- UL Recognized

USB PORT	01-USBPORT		-	-	-	-	-	\$ 166
----------	------------	--	---	---	---	---	---	--------



Description

- Passive USB-A Port with Increased Transfer Speed Up to 5 gbs/sec
- For Use with 01-DPORT4A and 01-DPORT4B
- Simultaneous Read/Write Capability
- Idle Device Power Saving State

PASSIVE USB-C ACCESSORY	01-PUSBC		-	-	-	1	0.2	\$ 98
-------------------------	----------	--	---	---	---	---	-----	-------



Description

- Passive USB-C Port ; Unit Provides Data Connection to Transfer Data Only, No Charging Capabilities
- Compatible with 01-DPORT4A and 01-DPORT4B
- Male/Female Connector

OPEN MARKET ONLY

Item	Model No.	Width	Depth	Height	Ship Wt	Cubic Ft	List Price
CHARGING USB-A+C ACCESSORY	01-USBAC	-	-	-	1	0.2	\$ 292



OPEN MARKET ONLY

Description

- For Charging Devices
- 20 Watt Power Supply
- USB+C Charging Port for 01-DPORT4A and 01-DPORT4B

VGA CONNECTOR ACCESSORY	01-VGACON	-	-	-	1	0.2	\$ 154
-------------------------	-----------	---	---	---	---	-----	--------

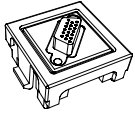

OPEN MARKET ONLY

Description

- VGA Port for 01-DPORT4A and 01-DPORT4B
- Enables Devices to Remote Display on Monitors
- 10' Cord
- Male/Female Connector

HDMI CONNECTOR ACCESSORY	01-HDMICON	-	-	-	1	0.2	\$ 128
--------------------------	------------	---	---	---	---	-----	--------

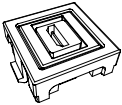

OPEN MARKET ONLY

Description

- HDMI Port for 01-DPORT4A and 01-DPORT4B
- Connects to High Definition Displays
- Female/Female Connector
- 18" Cord

VOICE COUPLER	01-VOICE1	-	-	-	-	-	\$ 75
---------------	-----------	---	---	---	---	---	-------

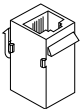
**Description**

- For Use with 01-DPORT4A and 01-DPORT4B
- 6-Pin Modular Plug
- Molded Black
- Cord Not included

DATA PORT	01-RJ4DATA	-	-	-	-	-	\$ 173
-----------	------------	---	---	---	---	---	--------

**Description**

- For Use with 01-DPORT4A and 01-DPORT4B
- 8-Pin Modular Plug, Cat6 Ethernet Cable, Pre-terminated Cable
- 10' Cord

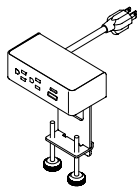
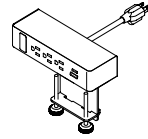
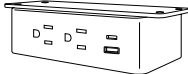
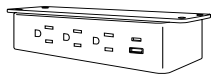
Item	Model No.		Width	Depth	Height	Ship Wt	Cubic Ft	List Price
DUO CLAMP WITH NEMA PLUG 	01-DUOCLAMPW	White	6½	3	7	1	0.2	\$ 591
	01-DUOCLAMPB	Black						
	01-DUOCLAMPS	Silver						
	Description <ul style="list-style-type: none"> Standard with: Two (2) Power Outlet, One (1) USB Charging Port and One (1) 60-Watt USB-C Power Delivery Port with GaN Technology with 10' Cord Clamps to Top and Features Silver Metal Trim Independent USB Circuit Controllers Deliver up to 2.1 Amps to Each Post All Mounting Hardware Included FCC Part 15A and UL Approved for Horizontal and Vertical Applications 							
TRIO CLAMP WITH NEMA PLUG 	01-TRIOCLAMPW	White	9	3	7	1	0.2	\$ 693
	01-TRIOCLAMPB	Black						
	01-TRIOCLAMPS	Silver						
	Description <ul style="list-style-type: none"> Standard with: Three (3) Power Outlets, One (1) USB Charging Port, One (1) 60-Watt USB-C Power Delivery Port with GaN Technology, One (1) Open Data with 10' Cord Clamps to Top and Features Silver Metal Trim Independent USB Circuit Controllers Deliver up to 2.1 Amps to Each Post HDMI, VGA, or RJ45 Sold Separately; See Accessories All Mounting Hardware Included FCC Part 15A and UL Approved for Horizontal and Vertical Applications 							
UNDERMOUNT DUO WITH NEMA PLUG 	01-DUOUNDERW	White	6½	2½	3	1	0.2	\$ 564
	01-DUOUNDERB	Black						
	01-DUOUNDERS	Silver						
	Description <ul style="list-style-type: none"> Sits Under Worksurface and Includes: Two (2) Power, One (1) USB Charging Port and One (1) 60-Watt USB-C Power Delivery Port with GaN Technology with 10' Cord All Mounting Hardware Independent USB Circuit Controllers Deliver up to 2.1 Amps to Each Post FCC Part 15A, UL Approved for Horizontal and Vertical Applications 							
UNDERMOUNT TRIO WITH NEMA PLUG 	01-TRIOUNDERW	White	9	2½	3	1	0.2	\$ 677
	01-TRIOUNDERB	Black						
	01-TRIOUNDERS	Silver						
	Description <ul style="list-style-type: none"> Sits Under Worksurfaces and Includes: Three (3) Power, One (1) USB Charging Port, One (1) 60-Watt USB-C Power Delivery Port with GaN Technology, One (1) Open Port and 10' Cord, All Mounting Hardware HDMI, VGA, or RJ45 Accessory for Open Port Specified Separately, See Accessories Independent USB Circuit Controllers Deliver up to 2.1 Amps to Each Post FCC Part 15A, UL Approved for Horizontal and Vertical Applications 							

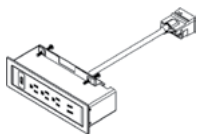
Item	Model No.		Width	Depth	Height	Ship Wt	Cubic Ft	List Price	
TRIO BEZEL WITH HARD WIRE CONNECTION 	Circuit 1								
	01-HWTRIOBEZELW1	White	9	2½	3	1	0.2	\$ 774	
	01-HWTRIOBEZELB1	Black							
	01-HWTRIOBEZELS1	Silver							
	Circuit 2								
	01-HWTRIOBEZELW2	White	9	2½	3	1	0.2	\$ 774	
	01-HWTRIOBEZELB2	Black							
	01-HWTRIOBEZELS2	Silver							
	Circuit 3								
	01-HWTRIOBEZELW3	White	9	2½	3	1	0.2	\$ 774	
	01-HWTRIOBEZELB3	Black							
	01-HWTRIOBEZELS3	Silver							
	Circuit 4								
	01-HWTRIOBEZELW4	White	9	2½	3	1	0.2	\$ 774	
	01-HWTRIOBEZELB4	Black							
	01-HWTRIOBEZELS4	Silver							

Description

- Must Specify Color and Circuit
- Sits on Worksurface and Includes: Three (3) Power, One (1) USB Charging Port and One (1) 60-Watt USB-C Power Delivery Port with GaN Technology, and All Mounting Hardware
- Independent USB Circuit Controllers Deliver up to 2.1 Amps to Each Post
- FCC Part 15A and UL Approved for Horizontal and Vertical Applications
- Maximum 6 Trio Units per Circuit
- Eight (8) Wire/Four (4) Circuit Hard Wire Power Unit
- HDMI, VGA, or RJ45 Sold Separately; [See Accessories](#)
- See Power Entry, Jumper Cable, and Quad Block Below and on Next Page

POWER ENTRY FOR HARD WIRE CONNECTION

01-HWPOWERENTRY			72	-	-	1	0.2	\$ 333
-----------------	--	--	----	---	---	---	-----	--------

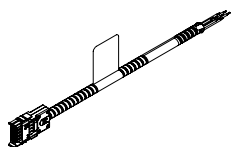
**Description**

- Eight (8) Wire/Four (4) Circuit Hard Wire Infeed
- UL183 Compliant

JUMPER CABLE FOR HARD WIRE CONNECTION

01-HW2JUMP			24	-	-	1	0.2	\$ 199
01-HW3JUMP			36	-	-	1	0.2	\$ 213
01-HW4JUMP			48	-	-	1	0.2	\$ 219
01-HW5JUMP			60	-	-	1	0.2	\$ 263
01-HW6JUMP			72	-	-	1	0.2	\$ 279

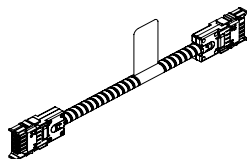
**Description**

- Eight (8) Wire/Four (4) Circuit Hard Wire Jumper
- UL183 Compliant

Item	Model No.	Width	Depth	Height	Ship Wt	Cubic Ft	List Price
QUAD BLOCK FOR HARD WIRE CONNECTION	01-HWQUADBLOCK				1	0.2	\$ 64

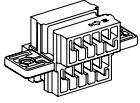

Description

- Eight (8) Wire/Four (4) Circuit Hard Wire Connector
- UL183 Compliant
- For Connecting Jumpers and Power Units
- Quantity of Four (4) Female Inputs

DUO BEZEL WITH PURL DAISY CHAIN PLUG

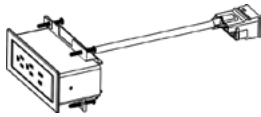

01-DCDUOBEZELW	White	6½	2⅝	3	1	0.2	\$ 631
01-DCDUOBEZELB	Black						
01-DCDUOBEZELS	Silver						

Description

- Standard with: Two (2) Tamper Resistant 15 Amp Power Outlets, One (1) USB-A Charging Port and One (1) 60-Watt USB-C Power Delivery Port with GaN Technology, 10' Cord and All Mounting Hardware
- Top Must Be Routed To Allow Unit to Sit Down Into the Top, Must Specify when Ordering Top
- Unit Supported By Attractive Slim Fit Bezel
- Requires Purl Daisy Chain Power Infeed, Specified Separately ([See Details](#))
- Non-Sequential System Allows up to Nine (9) Modules to be Connected with H-Block (See Below) and Jumper Cord ([See Details](#))
- Independent USB Circuit Controllers Deliver up to 2.4 Amps to Each Post
- FCC Part 15A, RU Listed and UL Recognized for Horizontal and Vertical Applications

TRIO BEZEL WITH PURL DAISY CHAIN PLUG

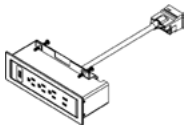

01-DCTRIOBEZELW	White	9	2⅝	3	1	0.2	\$ 723
01-DCTRIOBEZELB	Black						
01-DCTRIOBEZELS	Silver						

Description

- Standard with: Three (3) Tamper Resistant 15 Amp Power Outlets, One (1) USB-A Charging Port, One (1) 60-Watt USB-C Power Delivery Port with GaN Technology, One (1) Open Data, 12" Cord and All Mounting Hardware
- Top Must Be Routed To Allow Unit to Sit Down Into the Top, Must Specify when Ordering Top
- Unit Supported By Attractive Slim Fit Bezel
- Requires Purl Daisy Chain Power Infeed, Specified Separately ([See Details](#))
- Non-Sequential System Allows up to Nine (9) Modules to be Connected with H-Block and Jumper Cord ([See Details](#))
- Independent USB Circuit Controllers Deliver up to 2.4 Amps to Each Post
- FCC Part 15A, RU Listed and UL Recognized for Horizontal and Vertical Applications HDMI, VGA, or RJ45 Sold Separately ([See Accessories](#))

Item	Model No.	Width	Depth	Height	Ship Wt	Cubic Ft	List Price
PURL DAISY CHAIN POWER INFEEED	01-DCPOWER	-	-	-	1	0.2	\$ 227

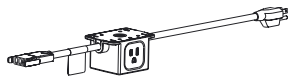

Description

- Includes One (1) 15 Amp Power Outlet, Nema Plug, One (1) Purl Connector Plug, and 25' Cord
- Powers up to Nine (9) Duo and Trio Purl Daisy Chain Units
- 15-Amp System Rating and Over-Current Protection
- System Requires H-BLOCK Connector Between Power Infeed and Each Jumper Cord, See Below For Purl Daisy Chain H-Block and Purl Daisy Chain Jumper Cords Details

PURL DAISY CHAIN H-BLOCK	01-DCHBLOCK	-	-	-	1	0.2	\$ 40
--------------------------	-------------	---	---	---	---	-----	-------

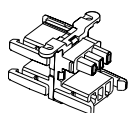

Description

- Includes One (1) Power In and Three (3) Power Out Receptacles
- System Requires H-BLOCK Connector Between Power Infeed and Each Jumper Cord, See Purl Daisy Chain Power Infeed (Above) and Jumper Cords (See Below)

PURL DAISY CHAIN JUMPER CORD	01-DC2JUMP	<i>24" Long</i>	-	-	-	1	0.2	\$ 72
	01-DC3JUMP	<i>36" Long</i>	-	-	-	1	0.2	\$ 77
	01-DC4JUMP	<i>48" Long</i>	-	-	-	1	0.2	\$ 82
	01-DC5JUMP	<i>60" Long</i>	-	-	-	1	0.2	\$ 87
	01-DC6JUMP	<i>72" Long</i>	-	-	-	1	0.2	\$ 92

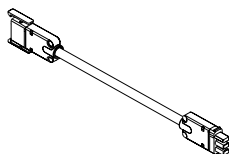

Description

- Connects Duo and Trio Daisy Chain Units
- Non-Sequential System Allows up to None (9) Modules to be Connected

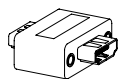

HDMI DATA PORT ACCESSORY	01-LCOMHDMI	-	-	-	1	0.2	\$ 171
--------------------------	-------------	---	---	---	---	-----	--------



Description

- HDMI Port for Trio Clamp and Trio Bezel Units

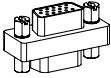
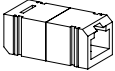
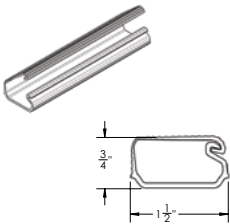
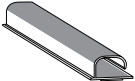
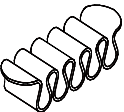
OPEN MARKET ONLY

Item	Model No.	Width	Depth	Height	Ship Wt	Cubic Ft	List Price
VGA DATA PORT ACCESSORY	01-LCOMVGA	-	-	-	1	0.2	\$ 125
 <p>Description</p> <ul style="list-style-type: none"> VGA Port for Trio Clamp and Trio Bezel Units 							
RJ45 DATA PORT ACCESSORY	01-LCOMRJ45	-	-	-	1	0.2	\$ 82
 <p>Description</p> <ul style="list-style-type: none"> RJ45 Port for Trio Clamp and Trio Bezel Units 							
WIRE MANAGEMENT CHANNEL	01-WMGR4	16	1½	1	1	-	\$ 120
 <p>Description</p> <ul style="list-style-type: none"> Set of Four (4) Black Plastic Wire Management Channels Snap Lock Channel Attaches with Adhesive Strips Ships via UPS Only 							
WIRE CHANNEL	01-32125	24	1%	1	.25	0.3	\$ 109
 <p>Description</p> <ul style="list-style-type: none"> Available in Black Channels Attach with Two (2) Double-Sided Installation Tape Open J Channel for Easy Storage of Cables 							
CABLE GRIP	01-WMGRCB	5%	1½	-	-	-	\$ 18
  <p>INSTALLATION VIEW</p> <p>Description</p> <ul style="list-style-type: none"> Under Surface Wire Management Black 							

Item	Model No.		Width	Depth	Height	Ship Wt	Cubic Ft	List Price
LINK 360 CABLE MANAGER	01-0251LINKSLV	Silver	5 3/16	3 9/16	30-51	4	3.0	\$ 403
	01-0251LINKBLK	Black	5 3/16	3 9/16	30-51	4	3.0	\$ 365

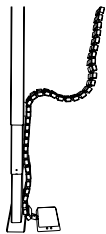

Description

- Kit Includes: 50 Link 360™ elements, One (1) Quad Connector, One (1) Dumbbell Connector, One (1) Foot Assembly with Two (2) Magnetic Clips
- Can Be Used For Height-Adjustable Mechanisms Up To 51" or Free-Standing Use

HEIGHT ADJUSTABLE WORKSTATION	01-S2SBLK		35 1/2	25	6-22	49	6.5	\$ 1553
	Black							

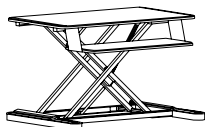

Description

- Height Adjustable
- Weight Capacity: 35lbs
- One-Handed Operation; Platforms Move Simultaneously
- Keyboard Platform: 10 1/2"D x 26 1/2"W
- Worksurface: 21"D x 35 1/2"W
- Can be Used on Worksurface 24"D x 35"W

28"D ELECTRIC HEIGHT ADJUSTABLE TABLE LIFT	01-2854ELB	Black	54-78	28	22-48	30	2.4	\$ 1892
	01-2854ELA	Silver						

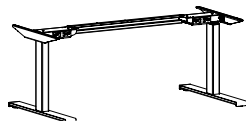

Description

- Standard with Up/Down Control Switch, 10.5' Power Cord, Integrated Anti-Collision Feature, Leveling Glides
- Standard Up/Down Control Switch can be Mounted for Left or Right Users; Upgrade to Advanced Memory Switch (01-MSWCH with Memory, Reminders, and Bluetooth), Must Specify and See Below for Details
- Adjusts to Accommodate Tops 54-78"W and 30"-36"D; Tops Sold Separately
- Lifting Capacity (Including Worksurface): 363 lbs
- Some Assembly Required; Installation Instructions Included

22"D ELECTRIC HEIGHT ADJUSTABLE TABLE LIFT	01-2254ELB	Black	54-78	22	22-48	58	2.4	\$ 1892
	01-2254ELA	Silver						



Description

- Standard with Up/Down Control Switch, 10.5' Power Cord, Anti-Collision Safety Feature, Leveling Glides
- Standard Up/Down Control Switch can be Mounted for Left or Right Users; Upgrade to Advanced Memory Switch (01-MSWCH with Memory, Reminders, and Bluetooth), Must Specify and See Below for Details
- Adjusts to Accommodate Tops 54-78"W and 24"D; Tops Sold Separately
- Lifting Capacity (Including Worksurface): 363 lbs
- Some Assembly Required; Installation Instructions Included

Item	Model No.		Width	Depth	Height	Ship Wt	Cubic Ft	List Price
22"D ELECTRIC HEIGHT ADJUSTABLE TABLE LIFT	01-2242ELB	Black	42-48	22	22-48	55	2.4	\$ 1892
	01-2242ELA	Silver						

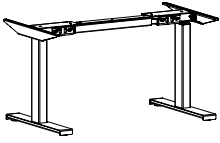

Description

- Standard with Up/Down Control Switch, 10.5' Power Cord, Anti-Collision Safety Feature, Leveling Glides
- Standard Up/Down Control Switch can be Mounted for Left or Right Users; Upgrade to Advanced Memory Switch (01-MSWCH with Memory, Reminders, and Bluetooth), Must Specify and See Below for Details
- Adjusts to Accommodate Tops 42-48"W and 24"D; Tops Sold Separately
- Lifting Capacity (Including Worksurface): 363 lbs
- Some Assembly Required; Installation Instructions Included

ELECTRIC HEIGHT ADJUSTABLE ADVANCED SWITCH WITH MEMORY	01-MSWCH		3 $\frac{3}{8}$	4 $\frac{3}{8}$	1 $\frac{1}{8}$	$\frac{1}{2}$	0.8	\$ 230
--	----------	--	-----------------	-----------------	-----------------	---------------	-----	--------



OPEN MARKET ONLY

Description

- Black Unit with Black Cord
- Bluetooth Capabilities
- Three Stand-Up Reminders
- Four Height Memory Positions

POWER STRIP	01-PRSP		9	2	2	1	-	\$ 212
-------------	---------	--	---	---	---	---	---	--------

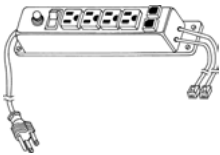

Description

- Includes Four (4) Outlets and Two (2) Phone Jacks
- Black Plastic with Rocker On/Off Switch
- 13 Amp Circuit Breaker
- 10' Power Cord and Two (2) 14' Phone Hook Up Cords
- UL Listed and CSA Certified
- Suitable for Surface or Recessed Mounting

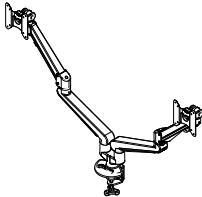
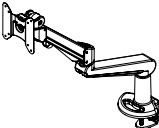
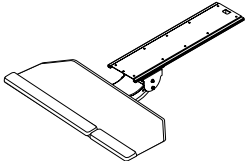
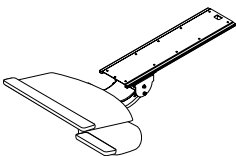
Item	Model No.		Width	Depth	Height	Ship Wt	Cubic Ft	List Price
DUAL ARTICULATING MONITOR ARM	01-MLEDGE2A	Aluminum	-	-	-	15	1.4	\$ 1356
	01-MLEDGE2B	Black						
	Description							
	<ul style="list-style-type: none"> • Includes Desk Clamp and Grommet Mount • Dual Mount with Independent Adjustment • 180° Lockout Feature. 6.5"H to 19.5"H Adjustment • 21" Monitor Extension, 3.5" Monitor Retraction • +30/-25° Monitor Tilt; 360° Swivel at Two Points • 17.6lb Weight Capacity per Arm • Enclosed Cable Management • VESA 75mm and VESA 100mm Compatible with Quick Monitor Release 							
SINGLE MONITOR ARM	01-MLEDGE1A	Aluminum	-	-	-	13	2.2	\$ 799
	01-MLEDGE1B	Black						
	Description							
	<ul style="list-style-type: none"> • Includes Desk Clamp and Grommet Mount • 180° Lockout Feature, 6.5"H to 19.5"H Adjustment • 21" Monitor Extension, 3.5" Monitor Retraction • +30/-25° Monitor Tilt • 17.6lb Weight Capacity • Enclosed Cable Management • VESA 75mm and VESA 100mm Compatible with Quick Monitor Release 							
ARTICULATING KEYBOARD CORNER PLATFORM	01-KB2CC		25	10½	4½	16	1.4	\$ 859
	Description							
	<ul style="list-style-type: none"> • Works with 17"+ Diagonal Work Surface; 25" Cut Corner Platform • Keyboard and Mouse on Same Level with Single Palm Rest on Both Sides • +/- 15° Tilt Adjustment & 360° Rotation • Independent Tilt Adjustment; Lift & Lock 7"H Adjustment • Cannot Be Used on 20"D Unit • Not Available with Optional Center Grommet • Track Measures 21" 							
	Options: Specify & Add							
	KB2CC	Factory Installed						\$ 215
KEYBOARD MECHANISM WITH KEYBOARD PLATFORM AND MOUSE TRAY AND PALM REST	01-KB3		26½	14	4.5	16	1.4	\$ 944
	Description							
	<ul style="list-style-type: none"> • 18¾" Platform with Swivel-Below Mouse Platform • Palm Rest for Mousing Surface • +/- 15° Tilt Adjustment & 360° Rotation • Independent Tilt Adjustment; Lift & Lock 7"H Adjustment • Cannot Be Used on 20" Deep Unit • Left or Right Handed Mouse Platform • Not Available with Optional Center Grommet • Track Measures 21" 							
	Options: Specify & Add							
	KB3	Factory Installed						\$ 215

Item	Model No.		Width	Depth	Height	Ship Wt	Cubic Ft	List Price
CPU HOLDER	01-CPUMINIA	Aluminum	-	-	-	16	.4	\$ 400

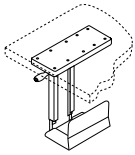

Description

- Vertically Mounts to Undersurface; No Tools Required for Adjustment
- 360° Swivel
- 13 $\frac{3}{8}$ " Ball Bearing Glide Track
- 3 $\frac{1}{4}$ "W-6"W and 16"H - 23"H Adjustment
- 55lb Load Capacity
- Fits CPU's 5"H - 20"H Overall Height

LED TASKLIGHT	TL-0824		22 $\frac{1}{2}$	7 $\frac{1}{8}$	1 $\frac{5}{8}$	-	-	\$ 380
	<i>84-LED, 7 Watts</i>							
LED TASKLIGHT	TL-0848		47 $\frac{1}{2}$	7 $\frac{1}{8}$	1 $\frac{5}{8}$	-	-	\$ 460
	<i>240-LED, 18 Watts</i>							



Description

- Includes the Power Supply and Three (3) Upper Wire Management Grommet
- Rocker Style On/Off Switch with 10' Power Cord
- Grommet Color will Match Lower Grommet Color

LED TASKLIGHT	01-47LED17		16 $\frac{3}{8}$	2	$\frac{3}{4}$	-	-	\$ 713
	<i>24-LED, 9.1 Watts</i>							
	01-94LED31		30 $\frac{1}{8}$	2	$\frac{3}{4}$	-	-	\$ 1234
<i>48-LED, 17.6 Watts</i>								
LED TASKLIGHT	01-188LED58		57 $\frac{1}{8}$	2	$\frac{3}{4}$	-	-	\$ 1702
	<i>96-LED, 33.7 Watts</i>							

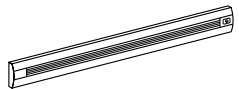

Description

- Includes the Power Supply and Three (3) Upper Wire Management Grommet
- 12' Power Cord
- Grommet Color will Match Lower Grommet Color
- Optional Occupancy Sensor Shuts Off After 30 Minutes of Inactivity and Turns On Immediately When Reentering the Detection Area

Options: Specify & Add

01-OSRP	Occupancy Sensor							\$ 378
---------	------------------	--	--	--	--	--	--	--------

Item	Model No.		Width	Depth	Height	Ship Wt	Cubic Ft	List Price
L SHELF  Must Specify (in this order): Model # Color	66-1530LS	64 lbs Weight Limit	30	15	17	30	6.0	T\$ 564
	66-1536LS	64 lbs Weight Limit	36	15	17	35	7.1	T\$ 621
	66-1542LS	90 lbs Weight Limit	42	15	17	40	8.2	T\$ 678
	66-1548LS	90 lbs Weight Limit	48	15	17	45	9.3	T\$ 732
	66-1554LS	90 lbs Weight Limit	54	15	17	50	10.5	T\$ 786
	66-1560LS	128 lbs Weight Limit	60	15	17	55	11.6	T\$ 842
	66-1566LS	128lbs Weight Limit	66	15	17	60	12.7	T\$ 898
	66-1572LS	154 lbs Weight Limit	72	15	17	65	13.8	T\$ 952
	66-1578LS	154 lbs Weight Limit	78	15	17	70	14.9	T\$ 1011
	66-1584LS	154 lbs Weight Limit	84	15	17	75	16.0	T\$ 1068
	66-1590LS	192 lbs Weight Limit	90	15	17	80	17.2	T\$ 1126
	66-1596LS	192 lbs Weight Limit	96	15	17	85	18.3	T\$ 1185

Description

- Weight Capacity is a Distributed Load
- Not Liable for Wall Mount Units that are not Properly Installed

Item	Model No.		Width	Depth	Height	Ship Wt	Cubic Ft	List Price
FLOATING SHELF  Must Specify (in this order): Model # Color	66-0930FS	40 lbs Weight Limit	30	9	1	6	0.7	T\$ 384
	66-0936FS	40 lbs Weight Limit	36	9	1	8	0.8	T\$ 425
	66-0942FS	57 lbs Weight Limit	42	9	1	9	0.9	T\$ 469
	66-0948FS	57 lbs Weight Limit	48	9	1	10	1.1	T\$ 510
	66-0954FS	57 lbs Weight Limit	54	9	1	12	1.3	T\$ 552
	66-0960FS	82 lbs Weight Limit	60	9	1	13	1.4	T\$ 591
	66-0966FS	82 lbs Weight Limit	66	9	1	14	1.5	T\$ 634
	66-0972FS	99 lbs Weight Limit	72	9	1	16	1.6	T\$ 677
	66-0978FS	99 lbs Weight Limit	78	9	1	16	1.8	T\$ 710
	66-0984FS	99 lbs Weight Limit	84	9	1	18	1.9	T\$ 743
	66-0990FS	123 lbs Weight Limit	90	9	1	19	2.1	T\$ 778
	66-0996FS	123 lbs Weight Limit	96	9	1	20	2.2	T\$ 811

Description

- Weight Capacity is a Distributed Load
- Not Liable for Wall Mount Units that are not Properly Installed

ACCESSORIES

MAGNETIC GLASS MARKER BOARDS

Item	Model No.	Width	Depth	Height	Ship Wt	Cubic Ft	List Price
MAGNETIC GLASS MARKER BOARD	GMB-5230W	30	½	52⅞	54	9.5	\$ 2522
COORDINATES WITH 30"H DESKS AND CREDENZA AND TALL WALL MOUNT HUTCHES OR SHELVING	GMB-5236W	36	½	52⅞	65	10.8	\$ 3000
	GMB-5242W	42	½	52⅞	76	12.2	\$ 3480
	GMB-5248W	48	½	52⅞	86	13.5	\$ 4120

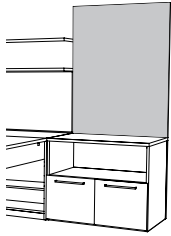

Description

- Available in Black (BLMKR) or White (WHMKR), Must Specify
- Mounting Brackets Included
- Coordinates With Tall Surface or Wall Mount Hutches
- See Rare Earth Magnets, Marker and Eraser Sets Below
- Find Additional Magnetic Glass Marker Boards in Caseloads Collections

Must Specify (in this order):

Model #
Color

MAGNETIC GLASS MARKER BOARD	GMB-5130W	30	½	51⅞	53	9.3	\$ 2432
FOR USE FROM FLOOR TO TOP OF UNIT	GMB-7030W	30	½	70⅞	72	12.1	\$ 3321
	GMB-8230W	30	½	82⅞	85	13.8	\$ 3853
	GMB-5136W	36	½	51⅞	63	10.6	\$ 2894
	GMB-7036W	36	½	70⅞	87	13.8	\$ 3961
	GMB-8236W	36	½	82⅞	102	15.8	\$ 4600

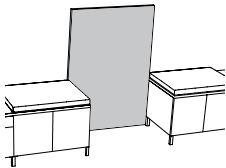

Description

- Available in Black (BLMKR) or White (WHMKR), Must Specify
- Marker Boards Are One (1) Piece with No Seams
- Mounting Brackets Included
- See Rare Earth Magnets, Marker and Eraser Sets Below
- Find Additional Magnetic Glass Marker Boards in Caseloads Collections

Must Specify (in this order):

Model #
Color

MARKER AND ERASER SET	01-MRKRSETBL	For Use with Black Marker Boards and Black Glass Doors	\$ 127
	01-MRKRSETWH	For Use with White Marker Boards and White Glass Doors	

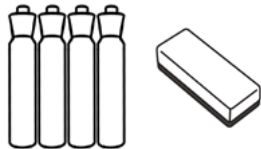

Description

- 01-MRKRSETWH May Also be Used with Standard Dry Erase Doors and Boards
- Includes Four (4) Markers and an Eraser

RARE EARTH MAGNET SET	01-MAGBL	Black Magnets	\$ 118
	01-MAGWH	White Magnets	



Description

- Includes Set of Five (5) Rare Earth Magnets
- To be Used with Tempered Glass Magnetic Marker Boards
- Comfort Grip with Stylish Protective Plastic Coating

23" TALL TOOL RAIL WORK WALL

FOR SURFACE OR WALL MOUNT HUTCHES AND 30"H CRENDENZA

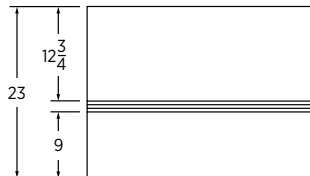

Must Specify (in this order):

- Model #
- Tackboard on Top or Bottom
- Dry Erase on Top or Bottom
- Tackboard Fabric Vendor, Pattern, and Color

Tackboard/Dry Erase Locations

- TB-TB: Tackboard Over Tackboard (Use Grade Prices)
- DEB-TB: Dry Erase Over Tackboard (Use Grade Prices)
- DEB-DEB: Dry Erase Over Dry Erase (Use Grade 1 Prices)

Model #	Size	COM ydg	COM, 1, 2 or 3	Grades										
				4	5	6	7	8	9	10				
WW-2330TRH	30"	1.00	\$ 693	839	907	976	1074	1177	1297	1435				
WW-2336TRH	36"	1.25	\$ 751	934	1019	1105	1227	1356	1506	1679				
WW-2342TRH	42"	1.25	\$ 770	953	1038	1124	1246	1375	1525	1698				
WW-2348TRH	48"	1.50	\$ 833	1052	1154	1258	1405	1559	1739	1946				
WW-2354TRH	54"	1.75	\$ 916	1172	1291	1411	1583	1763	1973	2215				
WW-2360TRH	60"	2.00	\$ 940	1232	1368	1506	1702	1908	2148	2424				
WW-2366TRH	66"	2.00	\$ 999	1291	1427	1565	1761	1967	2207	2483				
WW-2372TRH	72"	2.25	\$ 1057	1386	1539	1694	1914	2146	2416	2727				
WW-2378TRH	78"	2.50	\$ 1327	1692	1862	2035	2280	2537	2837	3182				
WW-2384TRH	84"	2.50	\$ 1378	1743	1913	2086	2331	2588	2888	3233				
WW-2390TRH	90"	2.75	\$ 1520	1922	2109	2298	2568	2851	3181	3561				
WW-2396TRH	96"	3.00	\$ 1617	2055	2259	2466	2760	3069	3429	3843				
WW-23102TRH	102"	3.25	\$ 1689	2164	2385	2609	2927	3262	3652	4101				
WW-23108TRH	108"	3.50	\$ 1772	2283	2521	2763	3106	3466	3886	4369				

Description

- Aluminum Tool Rail
- Work Walls 78" and Larger will Ship in 4 Pieces
- See Work Wall Accessories on Next Page

31" TALL TOOL RAIL WORK WALL

FOR USE WITH WALL MOUNT HUTCHES AND 21"H CRENDENZA

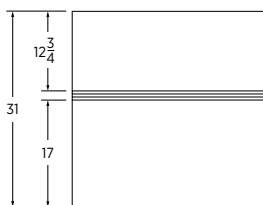

Must Specify (in this order):

- Model #
- Tackboard on Top or Bottom
- Dry Erase on Top or Bottom
- Tackboard Fabric Vendor, Pattern, and Color

Tackboard/Dry Erase Locations

- TB-TB: Tackboard Over Tackboard (Use Grade Prices)
- DEB-TB: Dry Erase Over Tackboard (Use Grade Prices)
- DEB-DEB: Dry Erase Over Dry Erase (Use Grade 1 Prices)

Model #	Size	COM ydg	COM, 1, 2 or 3	Grades										
				4	5	6	7	8	9	10				
WW-3130TTRW	30"	1.00	\$ 894	1040	1108	1177	1275	1378	1498	1636				
WW-3136TTRW	36"	1.25	\$ 971	1154	1239	1325	1447	1576	1726	1899				
WW-3142TTRW	42"	1.25	\$ 992	1175	1260	1346	1468	1597	1747	1920				
WW-3148TTRW	48"	1.50	\$ 1078	1297	1399	1503	1650	1804	1984	2191				
WW-3154TTRW	54"	1.75	\$ 1175	1431	1550	1670	1842	2022	2232	2474				
WW-3160TTRW	60"	2.00	\$ 1230	1522	1658	1796	1992	2198	2438	2714				
WW-3166TTRW	66"	2.00	\$ 1307	1599	1735	1873	2069	2275	2515	2791				
WW-3172TTRW	72"	2.25	\$ 1361	1690	1843	1998	2218	2450	2720	3031				
WW-3178TTRW	78"	2.50	\$ 1637	2002	2172	2345	2590	2847	3147	3492				
WW-3184TTRW	84"	2.50	\$ 1713	2078	2248	2421	2666	2923	3223	3568				
WW-3190TTRW	90"	2.75	\$ 1915	2317	2504	2693	2963	3246	3576	3956				
WW-3196TTRW	96"	3.00	\$ 2034	2472	2676	2883	3177	3486	3846	4260				
WW-31102TTRW	102"	3.25	\$ 2111	2586	2807	3031	3349	3684	4074	4523				
WW-31108TTRW	108"	3.50	\$ 2230	2741	2979	3221	3564	3924	4344	4827				

Description

- Aluminum Tool Rail
- Work Walls 78" and Larger will Ship in 4 Pieces
- See Work Wall Accessories on Next Page

Item	Model No.		Width	Depth	Height	Ship Wt	Cubic Ft	List Price
LEGAL TRAY	01-LGLTRAYC	Clear	14 $\frac{7}{8}$	10 $\frac{1}{2}$	1 $\frac{1}{8}$			\$ 119

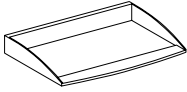

FOLDER SORTER	01-FLDRSRTRC	Clear	7 $\frac{1}{4}$	12 $\frac{3}{8}$	7 $\frac{1}{8}$			\$ 133
---------------	--------------	-------	-----------------	------------------	-----------------	--	--	--------

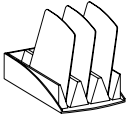

ACCESSORIES TRAY	01-ACCTRAYC	Clear	9 $\frac{1}{4}$	10 $\frac{1}{8}$	1 $\frac{1}{8}$			\$ 129
------------------	-------------	-------	-----------------	------------------	-----------------	--	--	--------

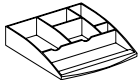

VESTA POWER CENTER	01-PDCTR		10 $\frac{3}{4}$	12	28 $\frac{1}{4}$	14	2.5	\$ 1835
--------------------	----------	--	------------------	----	------------------	----	-----	---------

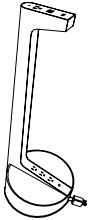

Description

- Top Includes One (1) Power Outlet, Two (2) USB Ports and One (1) USBC Port; Base Includes Three (3) Outlet
- Available in White
- 120" Power Cord
- Built with Weight Distribution for Optimal Stability
- Base is 5" Tall

Item	Model No.	Width	Depth	Height	Ship Wt	Cubic Ft	List Price
PLANTER BOX	01-1909PL	19¼	9½	6	16	2.0	T\$ 588

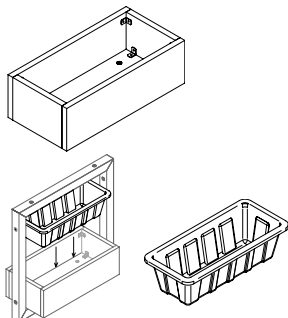

Description

- Material is TFL. Must Specify TFL (T) Color; [See Colors and Specify](#)
- Planter Will Ship with Attachment Hardware: Two (2) Black and Two (2) Nickel Bolts
- Horizontal Grain
- Planter Boxes Cannot be Installed on Both Sides of a Corner
- Optional Planter Box Insert Sold Separately

Option: Specify & Add

PBI	Planter Box Insert, Black Plastic						\$ 54
-----	-----------------------------------	--	--	--	--	--	-------

Must Specify (in this order):

- Model #
- TFL Color
- Optional Planter Insert

VISUAL BOARD	66-4848VB	48	5	48	150	11.0	T\$ 2861
--------------	-----------	----	---	----	-----	------	----------

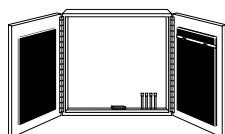

Description

- Standard with: Flipchart, Set of Four Dry Erase Markers, Eraser, Mounting Hardware, Tackboard on Each Door in Black Fabric, Display Rail with Adjustable Hooks for Flipchart
- Price Valid for Fabric Grades 1, 2, and 3, See Below For Higher Grade Fabric Pricing
- Does Not Feature Soft Close Hinges
- Magnetic Porcelain Non-Glare Writing Surface
- Find Textile Partners on Our Website; [Click Here](#)
- TFL Laminate Colors and Pulls can be Found Under Coordinating Caseloads Collections

Must Specify (in this order):

- Model #
- Color
- Tackboard Fabric Vendor, Pattern, and Color
- Pull
- Projection Screen Installation

Options: Specify & Add

		GRADE	4	5	6	7	8	9	10
TB-4214	Tackboard	\$	292	428	566	762	968	1208	1484
1-PS	Optional Factory Installed Projection Screen								\$ 1097

LECTERN STAND	88-2650LS	TFL+HPL	24	23	49	130	21.9	F, G, Y / T+P\$	1998
---------------	-----------	---------	----	----	----	-----	------	-----------------	------

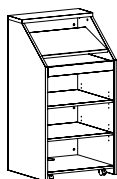

								H / T+P\$	2008
		Veneer+HPL						F, G, Y / W+P\$	3608
								H / W+P\$	3635
		Veneer						F, G, Y / W\$	3750
								H / W\$	3765

Must Specify (in this order):

- Model #
- Color

Description

- Top Edge Profiled on Approach Side Only (See Edge Options); Must Specify Edge Selection
- Fixed Shelf Angled for User Comfort, One (1) Pullout Shelf, and Two (2) Adjustable Shelves
- Two (2) Locking and Two (2) Non-Locking Casters
- Wire Management Grommet on Second and Bottom Shelf, Middle Shelf Features Wire Management Grommet Cut Out

Item	Model No.	List Price	
ECA TELECOM PLATES COMPATIBLE WITH:  Oasis Mini Power & Data 01-OASISMA, 01-OASISMB  Interact Power & Data 01-INTERACTG2A, 01-INTERACTG2B  Worksurface Power Center 01-INTRFCIA, 01-INTRFCIB	01-ABL	Telecom Plate, Blank Plate	\$ 42
	01-ABL737373	Telecom Plate, (3) RJ45 Cat 5e	\$ 379
	01-ABLAB	Telecom Plate, (1) RJ45 Cat 6, (1) RJ11 Cat 3 Phone	\$ 213
	01-ABLAB102	Telecom Plate, (1) RJ45 Cat 6, (1) RJ11 Cat 3, (1) USB W/72" Patch Cord	\$ 331
	01-ABLABB	Telecom Plate, (2) RJ45 Cat 6, (1) RJ11 Cat 3 Phone	\$ 331
	01-ABLB	Telecom Plate, (1) RJ45 Cat 6	\$ 154
	01-ABLBB	Telecom Plate, (2) RJ45 Cat 6	\$ 269
	01-ABLBBB	Telecom Plate, (3) RJ45 Cat 6	\$ 379
	01-ABLBBBB	Telecom Plate, (4) RJ45 Cat 6	\$ 492
	01-ABLBBC51	Telecom Plate, (2) RJ45 Cat 6, (1) 15 Pin HD VGA w/72" Patch Cord	\$ 461
	01-ABLBC51L	Telecom Plate, (1) RJ45 Cat 6, (1) Mini Stereo Inline, (1) 15 Pin HD VGA w/72" Patch Cord	\$ 424
	01-ABLC3811	Telecom Plate, (1) RJ45 Cat 6 Data Inline, (1) RJ11 Cat 3 Phone Inline	\$ 204
	01-ABLC45	Telecom Plate, (1) HDMI w/36" Patch Cord	\$ 305
	01-ABLC45C51L	Telecom Plate, (1) Mini Stereo Inline, (1) HDMI w/36" Patch Cord, (1) 15 Pin HD VGA w/72" Patch Cord	\$ 576
	01-ABLC51L	Telecom Plate, (1) 15 Pin HD VGA & (1) Mini Stereo Inline Jack	\$ 308
01-ABLCRDM	Telecom Plate, (3) Cord Bushings	\$ 99	

ORDERING INFORMATION

All orders should be emailed to neworders@indianafurniture.com. Orders can be faxed to 812-482-9035 or mailed to:

Indiana Furniture
P.O. Box 270, 1919 Hospitality Dr., Ste. A
Jasper, IN 47547-0270

ORDER PROCEDURE

All orders must include purchase order number, billing address, ship-to address and phone number, and any special instructions.

- purchase order number
- complete quantity for all units
- billing address
- model number
- ship-to address
- fabric (seating, tackboards, etc.)
- phone number
- finish
- any special instructions
- any other applicable option

Within each series, an example of "How to Order" is illustrated at the beginning of each series section. For further clarification, contact Customer Service.

PRICING

All prices shown are suggested retail prices F.O.B. Point of Origin, freight prepaid and allowed to one continental US destination. Prices, specifications and materials are subject to change without notice. Possession and/or distribution of this price list does not in itself constitute an offer to sell. Orders can be received only from authorized Indiana Furniture dealers. Orders will be billed at prices prevailing at time of shipment, unless acknowledged prior to the effective date of the price change, in which case billing will be at the price acknowledged.

ACKNOWLEDGMENT

All orders will be acknowledged promptly, showing how the order was entered, its approximate shipping date and other pertinent information. This acknowledgment is the final agreement between the customer and Indiana Furniture and is the exclusive statement of the terms thereof. Please examine this acknowledgment carefully and advise Indiana Furniture immediately of any discrepancies. Shipping fees are listed on direct bill contract orders and GSA, but not on commercial order acknowledgments or dealer-billed orders.

BUYER'S OBLIGATION: RIGHTS OF SELLER

If Indiana Furniture shall at any time doubt Buyer's financial responsibility, Indiana Furniture may decline to make shipments hereunder except upon receipt of cash payment in advance or security or other proof of responsibility satisfactory to Indiana Furniture. If buyer fails in any way to fulfill the terms and conditions set forth herein, Indiana Furniture may defer shipments until such default is corrected. Remedies provided herein shall be in addition to, and not in lieu of other remedies. Buyer agrees to abide by payment terms as listed on invoice. Buyer shall pay all reasonable costs and expenses, including attorney and collection fees, and late fees, incurred by Seller in connection with any amounts due for goods ordered.

CANCELLATIONS AND CHANGES

Due to immediate production on build-to-order items, all orders are considered firm and are not subject to cancellation or change without approval from Indiana Furniture. All approved changes are subject to additional charges and revised lead times.

PRODUCT DESIGN AND SPECIFICATION CHANGES

Indiana Furniture reserves the right to make changes in design and construction or discontinue products without prior notice. Note: All dimensions listed in price list are nominal.

REPAIR CHARGES

Indiana Furniture will only pay repair charges if Customer Service gives prior written authorization. No repair charge will be paid without advance approval at which time you will be issued a repair authorization number that will allow you to invoice Indiana Furniture for the completed work.

WAREHOUSE STORAGE CHARGES

If a shipment is held beyond 7 calendar days at your request, a **.084% per calendar day** (2.52% per month) storage charge will be assessed. The effective date will be 7 calendar days after the acknowledged ship date. Further, the prices applied to the order will be those in effect at the time of shipment.

DAMAGED MERCHANDISE

The consignee is responsible for filing claims with the carrier for damage and shortages. Claims for both obvious and concealed damage must be filed within 15 calendar days, and the damaged merchandise must not have been moved from the original receiving location. All damaged merchandise, including the cartons and packing materials, must be retained for inspection by either the carrier or by an Indiana Furniture Sales Representative. Indiana Furniture reserves the right to select the most cost effective way to repair or replace the damaged item. Once you have notified the carrier, please contact Customer Service for further assistance.

GENERAL INFORMATION + CONDITIONS OF SALE

Obvious Damage/Missing Cartons — Do not refuse merchandise damaged in transit. Indiana Furniture recommends the consignee inspect all merchandise upon arrival. If a shipment is received damaged or short, note all information on carrier's copy and your copy of freight bill and delivery receipt. Notify the delivering carrier and file a claim immediately. Pending the results of your claim, either Indiana Furniture or the carrier will cover 100% of the cost to repair or replace the damaged or missing item.

Concealed Damage — If concealed damage is discovered, notify the delivering carrier at once and request an inspection. This must be done within 15 calendar days of delivery. If the carrier will not perform the inspection, you should prepare an affidavit that you contacted them, noting the time and date, and that they failed to comply with your request. This, along with the other papers in your possession, will support the claim. Pending the results of your claim, the cost to repair or replace the item will be covered ½ by the carrier and ½ by Indiana Furniture for shipments less than a full truckload and 100% by Indiana Furniture for shipments of full truck loads.

RETURN MERCHANDISE

Merchandise will not be accepted for return without a RGA (Return Goods Authorization) issued by Indiana Furniture. We will consider issuing RGA's for the following reasons:

1. Manufacturing defect (inspected by Indiana Furniture representative)
2. Indiana Furniture order processing error
3. Shipping error
4. Mis-marked cartons
5. Duplicated shipments

If you have any questions as to whether your reason for return qualifies for consideration, please contact your Customer Service Representative. Merchandise must be returned within 60 days of the RGA issued date, or within 60 days upon receipt of replacement product to receive credit. Returns due to mis-marked cartons must also be returned in the original cartoning, with shipping labels intact, to receive credit.

All merchandise being returned must be properly packed and protected to ensure no further damage is incurred during transportation back to an Indiana Furniture facility. Upon receipt, all returned merchandise will be thoroughly inspected and the results compared to the reason for return stated on the RGA. Any discrepancies, such as additional damage, signs of usage, missing parts, etc., will result in an adjustment to the amount of credit issued.

DELIVERY AND FREIGHT CHARGES

All shipments are F.O.B. Point of Origin, Jasper, IN, freight prepaid and allowed dock to dock on 53' trailer. Ownership and responsibility of the merchandise becomes that of the buyer upon delivery to the freight company. Shipments into Alaska, Hawaii, Canada, Mexico, Puerto Rico and other exports are freight prepaid and allowed to port of exit.

Indiana Furniture reserves the right to select the most appropriate carrier and routing on all shipments. Indiana Furniture will attempt to accommodate requests for favored carriers and delivery times. Deliveries requested Monday through Thursday, after 3pm, will be assessed a \$300 per truck after hours fee. Deliveries requested after 3pm on Friday or on weekends, will be assessed a \$600 per truck weekend delivery fee.

Inside delivery and installation services are not included in the pricing shown. Any deviation from dock-to-dock delivery, such as but not limited to, non-dock, residential, or inside delivery must be specified on the order. Should these services be requested or required, all charges incurred will be charged to the "Sold To" of the order.

Shipments totaling less than \$3000 (net value, product only) will be assessed a small order fee of \$300 net per shipment. This fee will be reduced for items shipped via small package carriers. For order shipments of \$100 or less, shipped by small package carrier, the fee is \$22. For order shipments over \$100, shipped by small package carrier, the fee is \$40. All shipping fees will be added at the time of invoicing.

BIFMA AND ANSI TESTING

Indiana Furniture is a member of the Business and Institutional Furniture Manufacturer's Association (BIFMA). Tests developed by the BIFMA and approved by the American National Standards Institute (ANSI) determine the strength and durability of casegoods and seating in its everyday use. Although this testing does not serve as a warranty or guarantee, Indiana Furniture products within this price list have been tested by an independent verifying body and meet or exceed applicable BIFMA and ANSI standards.

Subject to the limitations set forth in this warranty, Indiana Furniture Industries, Inc. (“**Indiana Furniture**”) warrants to the original purchaser all product in this price list (“**Product**”) to be free from defects in material and workmanship given normal use for a 12-year period from the date of manufacture. During the applicable warranty period, Indiana Furniture, as its sole obligation, will repair or replace (in Indiana Furniture’s sole discretion) any Product, part, or component covered by this warranty and sold after June 2, 2025, which fails under normal use as a result of a defect in material or workmanship. Normal use is defined as the equivalent of a single shift, 40-hour work week. Indiana Furniture will repair or replace the defective Product, part, or component with a comparable Product, part, or component.

Warranty periods are limited for certain Products and parts as follows:

12-year Warranty (from the date of manufacture)

- Seating Mechanisms
- Veneers
- Laminates
- Casters and Glides

5-year Warranty (from the date of manufacture)

- Triple Play Series
- Electrical Components
- Pneumatic Cylinders
- Textiles, Foam, and Decorative Trim
- Swivel Arm Pads
- Keyboard Kits
- Lighting
- All Height Adjustable Mechanisms

3-year Warranty (from date of shipment)

- Dock 950 Wireless Charger
- Dock 150 Wireless and USB Charger

THIS WARRANTY DOES NOT COVER:

- Damage caused by a carrier or third party
- Normal or routine wear and tear
- Appearance, durability, quality, behavior, colorfastness, or any other attribute of customer’s own materials or any non-standard Indiana Furniture material (including CF Stinson, Maharam, Momentum, Mayer, UltraFabrics, Architex, and other alliance programs) specified by the customer and applied to a Product
- Color, grain or texture of wood, laminate and other covering materials
- Changes in wood or fabric color due to aging or exposure to light

As the manufacturer of the Product, Indiana Furniture stands behind its craftsmanship and pledges to do everything it can to reasonably resolve, as quickly as possible, any problems you may have with the Product within the terms and conditions of this warranty.





If you encounter a defect covered by the foregoing warranty, contact the dealer from whom you purchased the Product. If the dealer is unable to resolve your warranty issues, you should contact Indiana Furniture. Please ensure that you have all of the pertinent facts when contacting the dealer or Indiana Furniture, including the model number and factory order number from the inspection label attached to the Product.



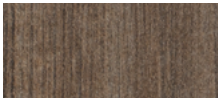

INDIANA FURNITURE IS NOT PROVIDING, AND SPECIFICALLY DISCLAIMS, ANY OTHER WARRANTIES FOR THE PRODUCTS, EXPRESS OR IMPLIED, INCLUDING ANY IMPLIED WARRANTY OF MERCHANTABILITY OR FITNESS FOR A PARTICULAR PURPOSE. INDIANA FURNITURE SHALL NOT BE LIABLE TO THE PURCHASER OR ANY THIRD PARTY FOR CONSEQUENTIAL, INCIDENTAL, INDIRECT, OR SPECIAL DAMAGES, INCLUDING, WITHOUT LIMITATION, DAMAGES ARISING OUT OF OR RESULTING IN ANY MALFUNCTIONS, DELAYS, LOSS OF PROFIT, INTERRUPTION OF BUSINESS, PERSONAL INJURY, BODILY INJURY, DEATH, DISMEMBERMENT, OR PROPERTY DAMAGE.

Indiana Furniture Industries, Inc.
Attn: Customer Service
1919 Hospitality Dr., Ste. A
P.O. Box 270
Jasper, Indiana 47547-0270
800.422.5727
Fax 812.482.9035
custserv@indianafurniture.com

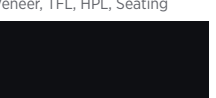
Surface Materials

Wood Finishes and Woodgrain, and Solid Laminates





			
---	---	---	---

* Finish is Low Sheen



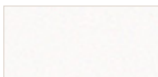

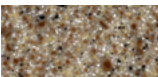
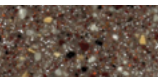
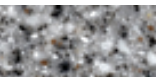



Frosted & High Gloss Acrylics

				
---	---	---	---	--

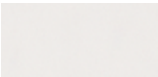
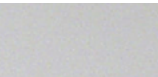

Solid Surfaces

					
---	---	---	---	--	---

Metal Options

Glass Options

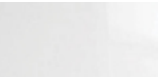
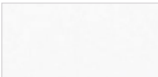
Colors represented are high-resolution reproductions and may vary slightly from the actual product. To order samples, please contact our Customer Service team or order online at www.indianafurniture.com. Graining and finish colors may vary, yet will continue to complement, across Veneer, HPL, TFL, and Seating products due to the inherent differences of these materials.

Indiana[®]

FURNITURE

1919 Hospitality Drive, Suite A
PO Box 270
Jasper, Indiana 47547-0270

Tel 812.482.5727

Toll 800.422.5727

Fax 812.482.9035

sales@indianafurniture.com

www.indianafurniture.com

Federal Classification: Small Business

©2025 Indiana Furniture 6/25

