

Media Table Assembly Instructions

Components:

- 7/8" PFH Screws
- 5/8" PPH Screws
- 1/2" PPH Screws
- 1/4"-20 x 1-3/4" Bolts
- 4" L Brackets
- 18" L Brackets
- Furniture Cam Connectors
- Dowels

- 1** Fasten stretcher rails between base ends using post/cam connections in locations shown. Insert Furniture Cam Connectors into holes in locations shown on inside of stretcher rails and dowels into appropriate holes on edge. Turn cam clockwise to tighten to post.
- 2** Secure stretcher rails to base ends using 1/4"-20 x 1-3/4" Bolts in pilot holes in stretcher rails in locations as shown into threaded inserts in base uprights. Ensure all top edges are flush and level the unit using the adjustable glides on bases.
- 3** Further secure stretcher rails to base ends using 4" L Brackets and 5/8" PPH Screws in locations as shown.

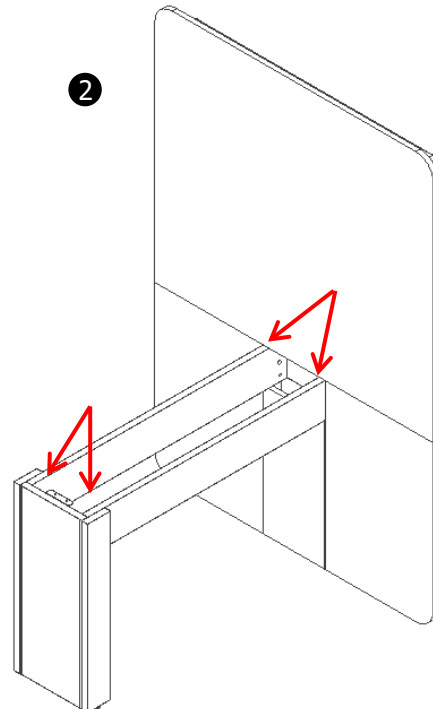
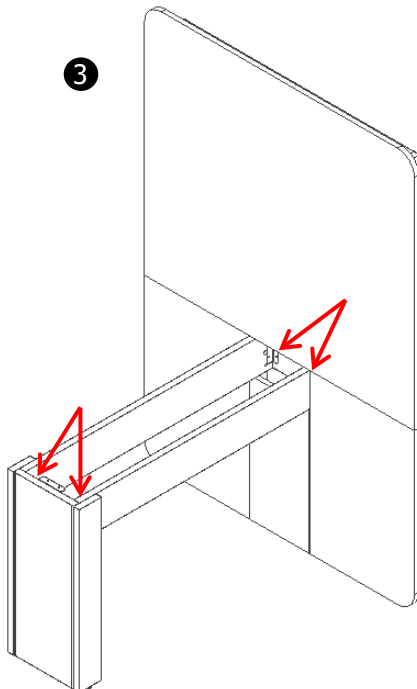
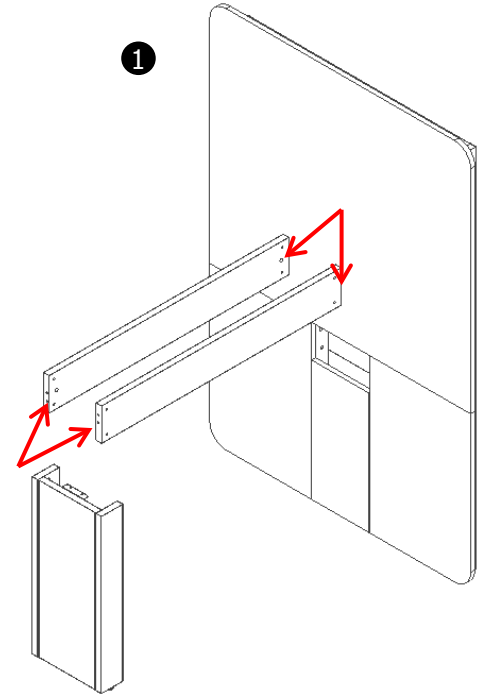

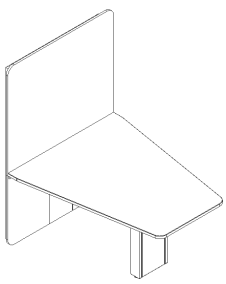

Media Table Assembly Instructions

- 5 Secure the top to chassis using 18" L Brackets on stretcher rails and back panel as shown. Use 1/2" PPH Screws to fasten brackets to stretcher rails and back panel and use 7/8" PFH screws to fasten brackets to top. Ensure top remains level.
- 6 To access wire management channels, remove doors on insides of each base as shown below. (top and stretcher rail removed for clarity)
- 7 To mount optional Low Profile TV Mount, follow instructions provided by manufacturer, using pilot holes drilled in back panel as shown.

