

Rectangle Panel Base | Indiana FURNITURE

with Trough Attachment & Placement Assembly Instructions

Components:

- Rectangle Panel Base
- Stretcher Rails
- Screws, 5/8" PPH – 4 per 4" L Bracket, , 20 per Joiner Plate
- Screws, 7/8" PPH – 10 per 18" L Bracket
- 4" L Brackets – 2 per Stretcher Rail
- 18" L Brackets – 1 per Base, 1-3 per Stretcher Rail
- Zip bolts – 4 per joining plane on multi-piece tops
- Joiner Plate – 1 per pair of Zip Bolts

- 1 Attach Stretcher Rails to Panel Base by first securing post & cam connections. Keep top edges flush.
- 2 Attach 4" L Brackets to inside face of Stretcher Rails and Base, using 5/8" PPH screws, centered along short edge as shown. Keep top edge of bracket flush with short edge of base. Do not obstruct cam holes. Ensure tops of Stretcher Rails are flush with tops of Bases.
- 3 Install Wire Management channel as needed.

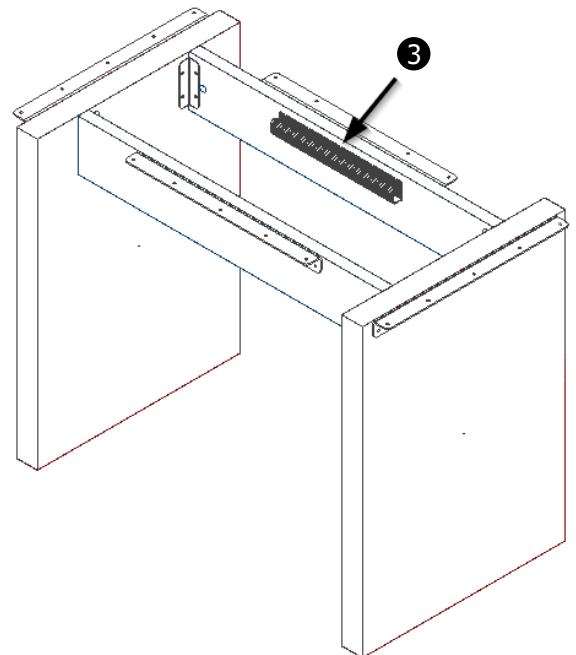
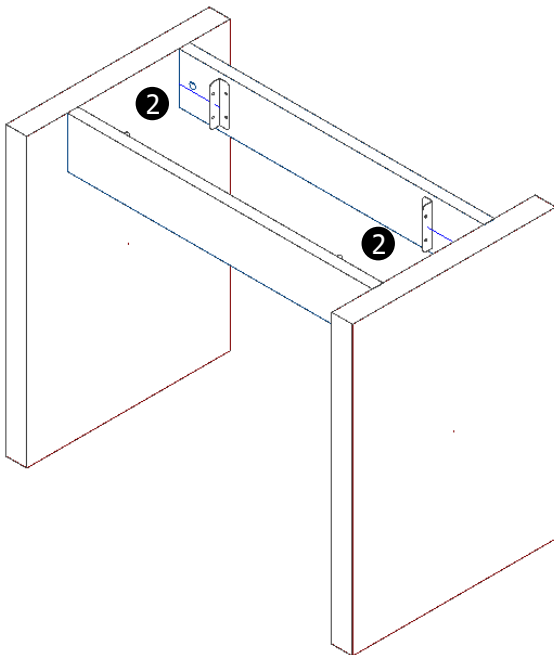
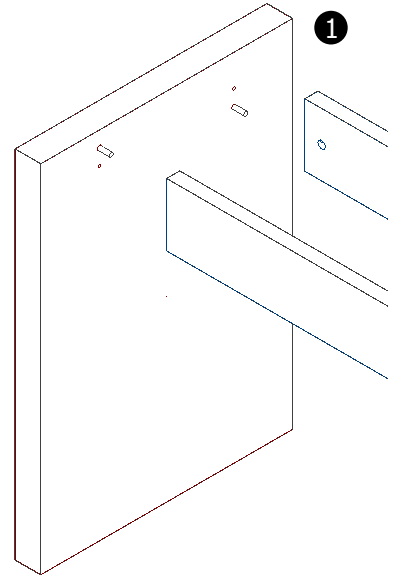

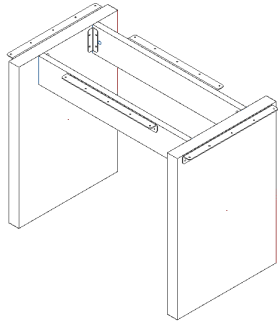

Rectangle Panel Base | Indiana FURNITURE

with Trough Attachment & Placement Assembly Instructions

One Piece Top

- 4 Measure and mark base/stretchers placement and overhang on bottom of table top. Base should be centered along table top width with 15" or 19" inset, such that base is centered along table top length.
- 5 Position bases/stretchers and secure with 18" L Brackets and included screws.

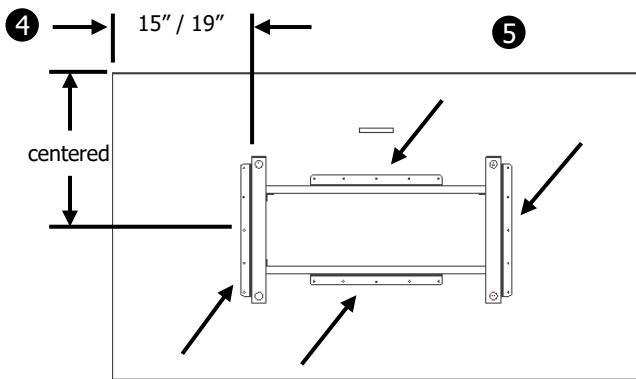

Multi-Piece Top

- 4 Insert Zip Bolts into cutouts between tops as shown. Tighten and ensure edges of tops remain flush.
- 5 Assemble Joiner Plate to top over Zip Bolts. Zip Bolts should be accessible through Joiner Plate cutouts for adjustment.
- 6 Measure and mark base/stretchers placement and overhang on bottom of table top. Base should be centered along table top width with 15" or 19" inset, such that base is centered along table top length.
- 7 Position top on bases/stretchers and secure with 18" L Brackets and included screws.

