

# Cylinder Bases | Indiana FURNITURE

## Attachment & Placement For 1-Piece Tops Assembly Instructions

### Components:

- Screws, 5/8" PPH – 8 Per Cylinder Base
- Screws, 1 3/4" PFH – 8 Per Cylinder Base
- Adjustable Glides – 5 Per Cylinder Base

**1** Insert adjustable glides into base bottom.

**2** Follow chart for base inset dimension.

Top size	Base inset	Cylinder base
36" x 72"	x = 15"	16"
36" x 84"	x = 17"	16"
36" x 96"	x = 19"	16"
42" x 72"	x = 15"	20"
42" x 84"	x = 17"	20"
42" x 96"	x = 19"	20"
48" x 72"	x = 15"	20"
48" x 84"	x = 17"	20"
48" x 96"	x = 19"	20"

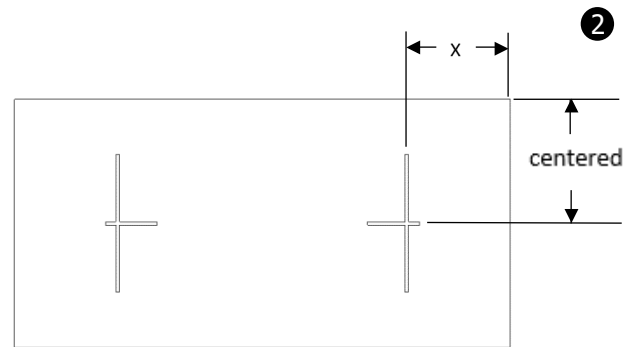

**3**

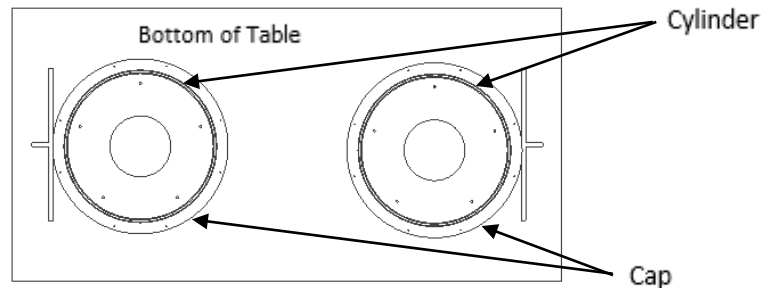

**3** Measure and mark base inset on table bottom.

**4** Put bases in place. Attach bases to bottom of table with 1 3/4" screws.

**4**

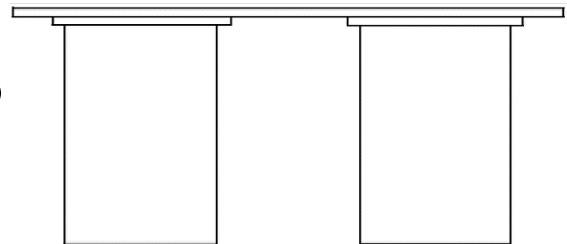

Side view of Table after Attachment

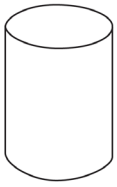

# Cylinder Bases | Indiana FURNITURE

## Attachment & Placement For Circular Tops

### Assembly Instructions

#### Components:

- Screws, 5/8" PPH – 8 Per Cylinder Base
- Screws, 1 3/4" PFH – 8 Per Cylinder Base
- Adjustable Glides – 5 Per Cylinder Base

1 Insert adjustable glides into base bottom.

2 Follow chart for center dimensions.

Top size	Center dimension	Cylinder base
36"	x = 18"	16"
42"	x = 21"	20"
48"	x = 24"	20"
54"	x = 27"	30"
60"	x = 30"	30"

3 Measure and mark center location on bottom of table.

4 Center cylinder base in location. Attach base to bottom of table with 1 3/4" screws.

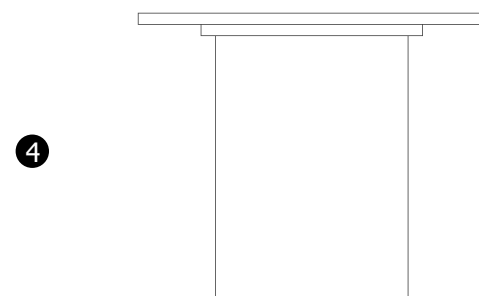
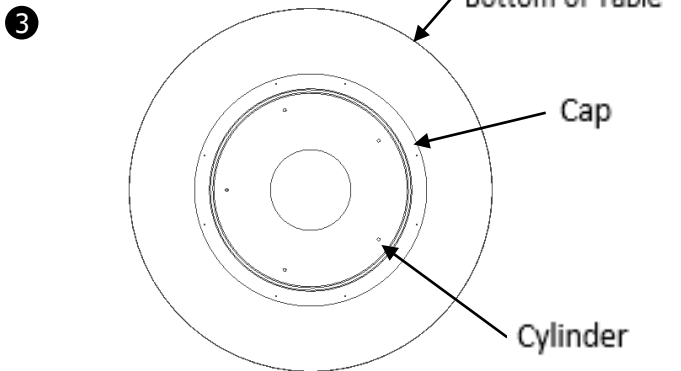
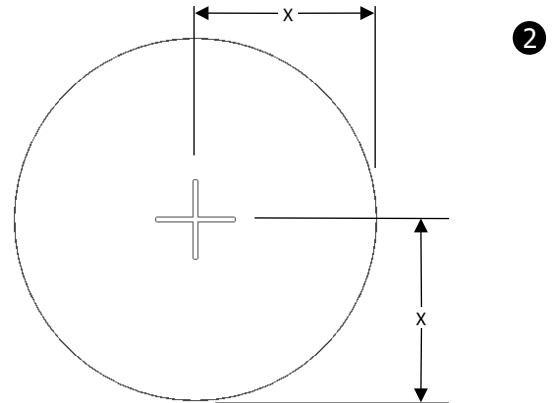

Side view of Table after Attachment

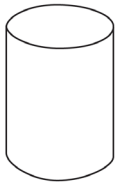

# Cylinder Bases | Indiana FURNITURE

## Attachment & Placement For Square Tops Assembly Instructions

### Components:

- Screws, 5/8" PPH – 8 Per Cylinder Base
- Screws, 1 3/4" PFH – 8 Per Cylinder Base
- Adjustable Glides – 5 Per Cylinder Base

1 Insert adjustable glides into base bottom.

2 Follow chart for center dimensions.

Top size	Center dimension	Cylinder base
30"	$x = 15"$	16"
36"	$x = 18"$	20"
42"	$x = 21"$	20"
48"	$x = 24"$	30"

3 Measure and mark center location on bottom of table.

4 Center cylinder base in location. Attach base to bottom of table with 1 3/4" screws.

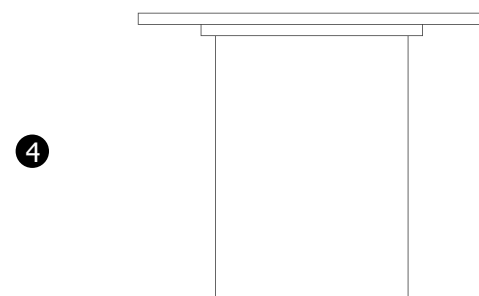
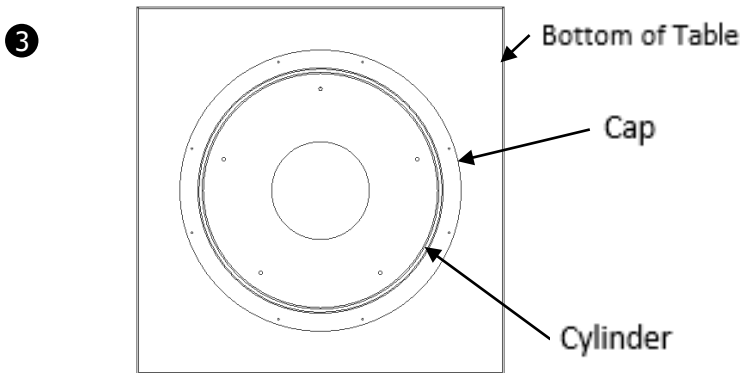
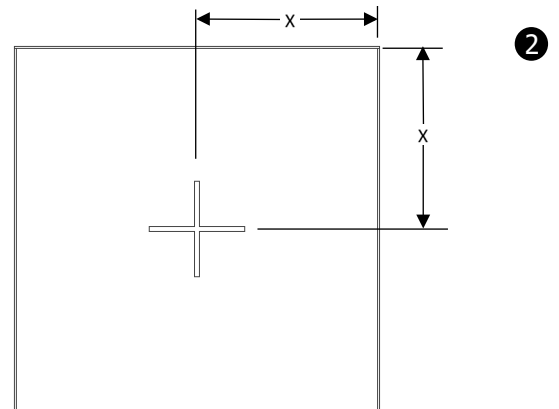

Side view of Table after Attachment