

Y-Leg Meeting Table | Indiana FURNITURE

Assembly Instructions

Components:

- Work Surface (Qty 1)
- Trough Assembly (Qty 1)
- Top Plates (Qty 2)
- Feet (Qty 2)
- #12 x 1" Pan Head Wood Screws (Qty 16)
- #8 x 5/8" Pan Head Wood Screws (Qty 12)
- 1/4"-20 x 1" Flat Head Socket Cap Screws (Qty 16)

Tools Needed:

- Drill with Phillips Screw bit
- 5/32" Allen Wrench

1 Using the 1/4"-20 x 1" Flat Head Socket Cap Screws, bolt the top plates on the Trough assembly as shown.

2 With the work surface on the floor, screw the assembly from Step 1 onto the top using the #12 x 1" and the #8 x 5/8" wood screws. Location or screw holes are provided.

Note: If you ordered a surface mount power unit, install the power unit in the Work Surface **before** fastening the trough assembly in step 2.

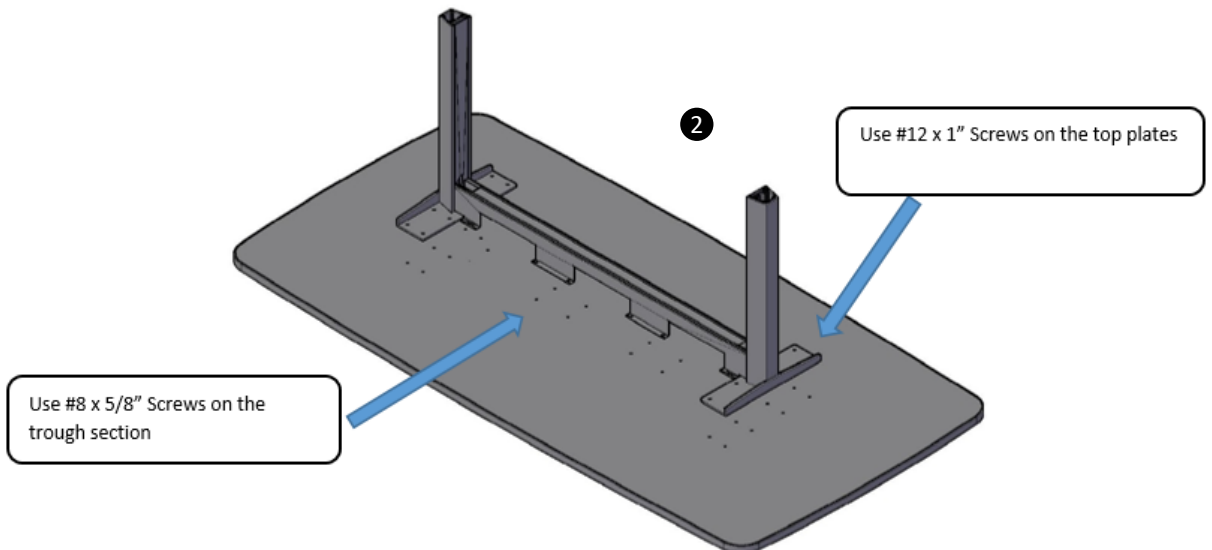
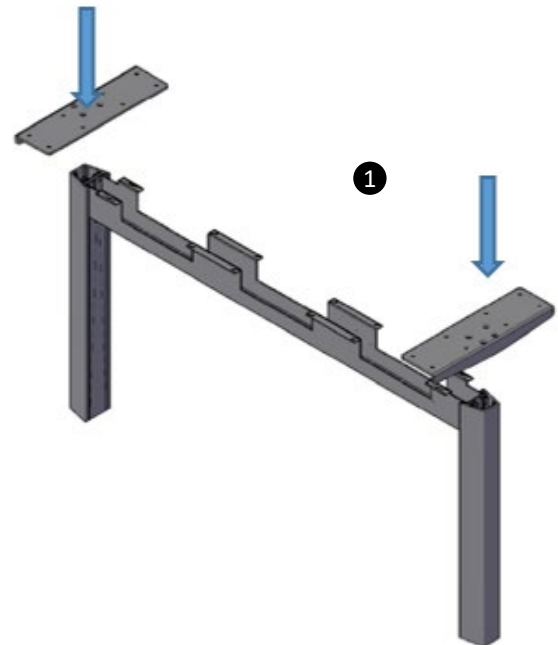

Y-Leg Meeting Table | Indiana FURNITURE

Assembly Instructions (continued)

3 Next Bolt the Feet onto the leg posts using the 1/4"-20 x 1" Socket Head Cap Screws and the 5/32" Allen Wrench.

4 Flip the Table over and level it accordingly using the adjustable glides.

Note: The table comes equipped with removable wire management covers as shown below. If it is necessary to route wires down the leg, you may rotate the wire management cover so the notch is at the bottom to allow for wires to exit.

