

# Height Adjustable Panel Leg | Indiana FURNITURE

## Assembly Instructions

### Components:

- Height Adjustable Panel Leg
- Worksurface (HTP model)
- T-Support
- Top Mount L-Brackets (Qty 2)
- #10 X 7/8 PPH Zinc Screws (Qty 12)
- M6-16mm Black Screws (Qty 6)

- 1** Attach T-support and L-Brackets to Height Adjustable Leg using M6-16mm screws.

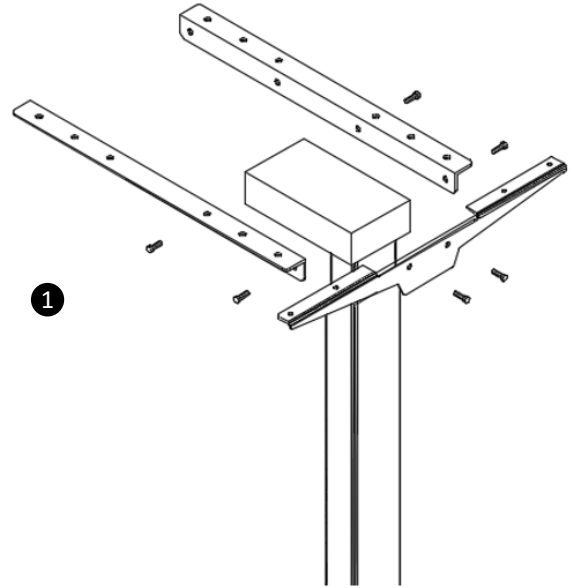

- 2** Attach worksurface by lining up L-Bracket holes with the highlighted holes shown below. Use #10 X 7/8 PPH screws provided.

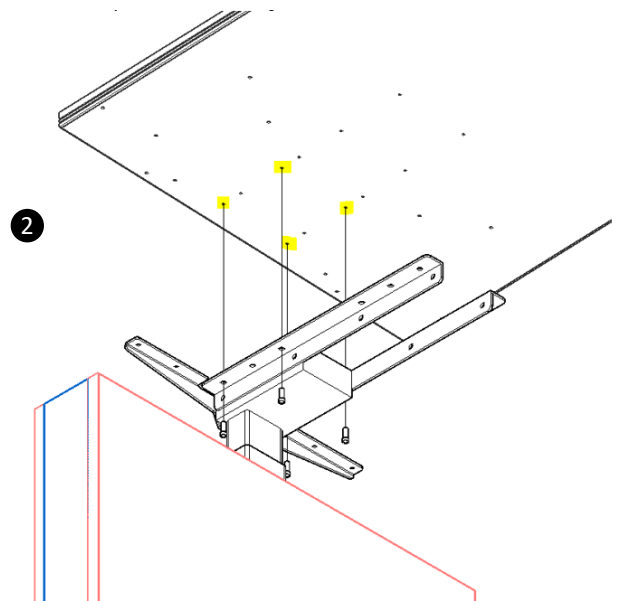

- 3** Fill remaining eight L-Bracket holes and four T-Support holes. Use #10 X 7/8 PPH screws provided.

*(Please note we only have alignment markers for the first four holes. All other markers are for other applications.)*