

395CGT Table Bracket | Indiana FURNITURE

Assembly Instructions

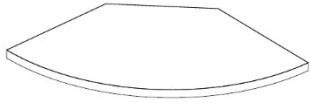

- 1 Attach the 2 (two) 2209-00395T – L Bracket to the side frame of the Gleem+ chair using 4 (four) 2202-01078 - #10 x 7/8 Pan Head Screws. 2 (two) screws per bracket.

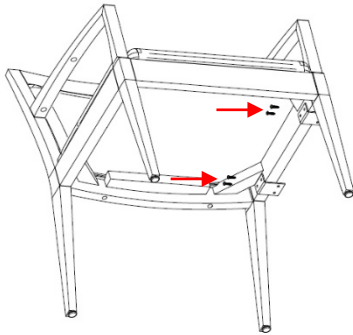

The 2 (two) 2209-00395T – L Bracket should be placed as shown.

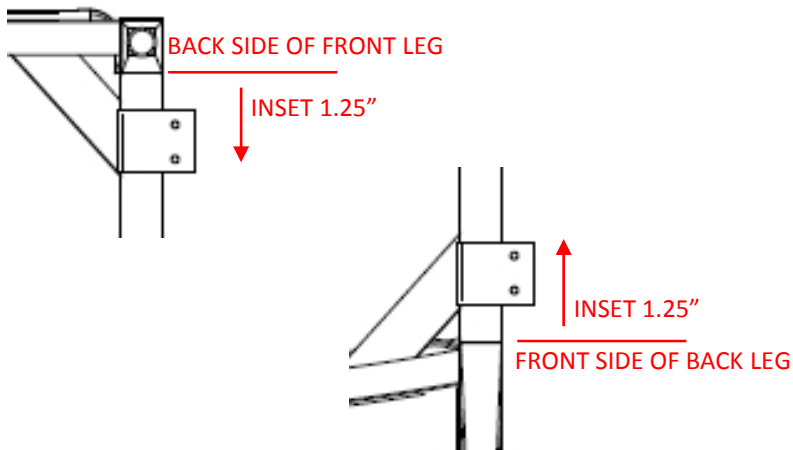

- 2 Repeat Step 1 for the second Gleem+ chair.
- 3 Attach the 395CGT to Gleem+ chair by aligning the front edge of the table with the back of the front leg. Attach using 4 (four) 2202-01078 - #10 x 7/8 Pan Head Screws. 2 (two) screws per bracket.

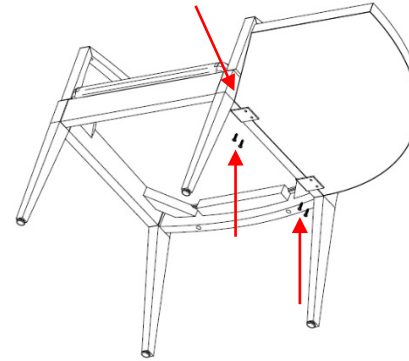

- 4 Repeat step 3 on the second Gleem+ chair.
- 5 395CGT is now installed.

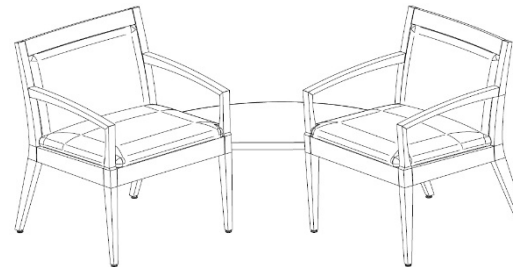

395CGT Table Bracket | Indiana FURNITURE

Assembly Instructions

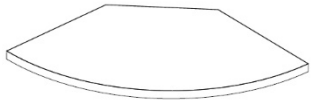

Disassembly

- 1 Unscrew 8 (eight) 2202-01078 – #10 x 7/8 Pan Head Screw. 2 (two) screws per bracket.

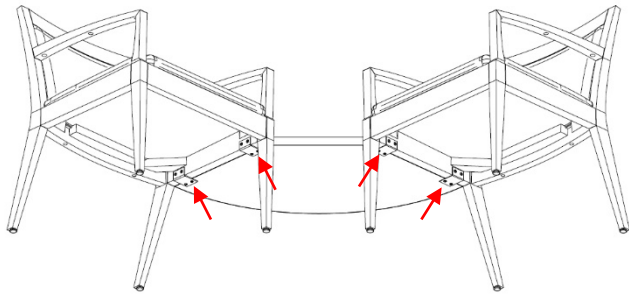

- 2 Remove 395CGT.

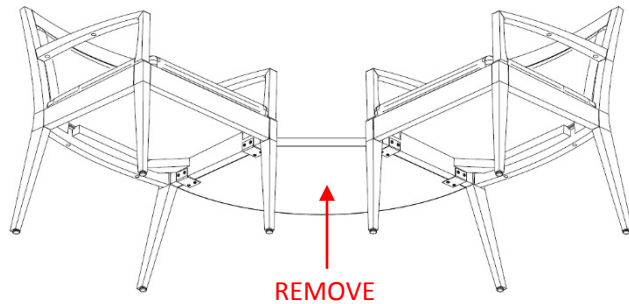

- 3 Unscrew 4 (four) 2202-01078 - #10 x 7/8 Pan Head Screw. 2 (two) screws per bracket.

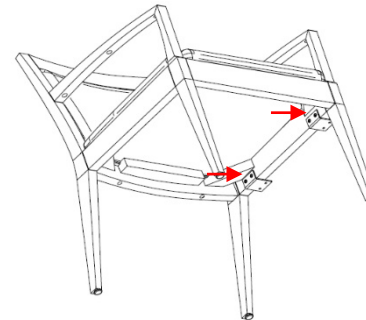

- 4 Remove 2 (two) 2209-00395T – L Bracket.

