

One 10 Block: 5 Piece Conference Table Assembly Instructions 96" to 120" Lengths

Parts List:

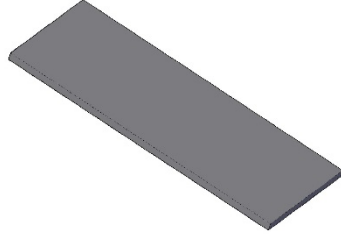

Qty (2) Short Tops

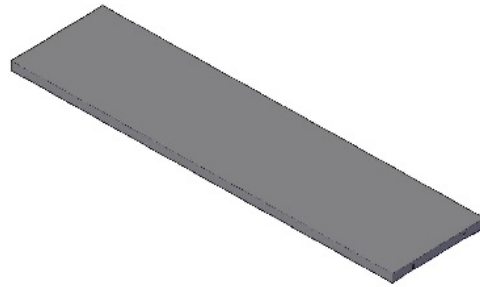

Qty (2) Long Tops

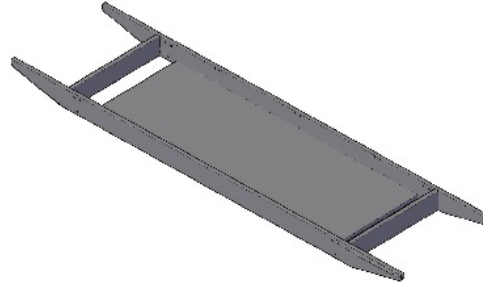

Qty (1) Trough Assembly

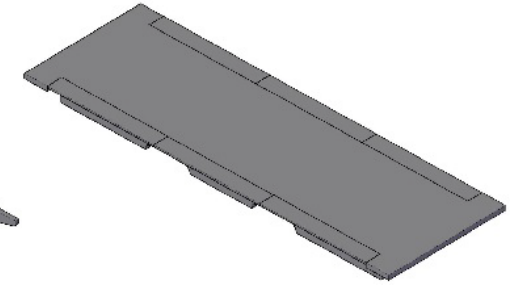

Qty (1) Accent Cover

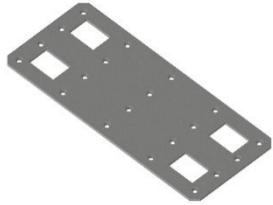

Qty (4) Jointer Plates



Qty (8) Jointer Bolts

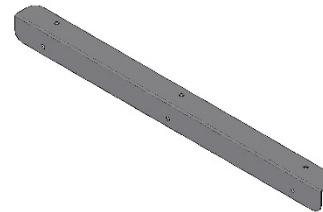

Short L-Brackets

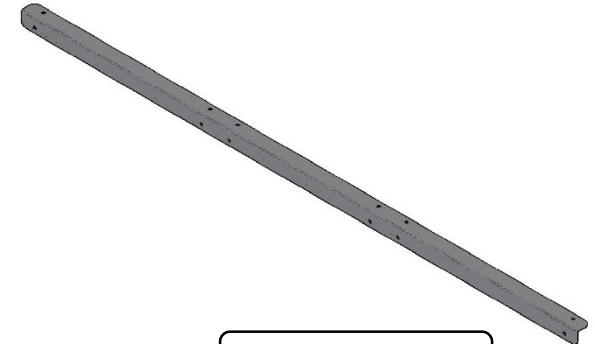

Long L-Brackets

Hardware Included

- Bag of #10 x 3/4 " Pan Head Screws
- Bag of 1/4"-20 x 2-3/8" Bolt and 1/4"-20 Nuts
- (1) 29mm Silver Polycom Grommet (Optional)
- (12) Cover Caps (Optional)

Tools Required

- (2) People
- Drill with phillips screw bit
- 5/32" Allen Wrench
- 5mm Allen Wrench
- 10mm Wrench
- Level
- 1" Hole Saw Bit for Polycom Grommet (Optional)

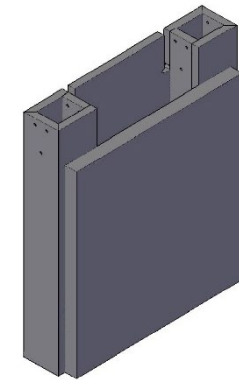

Qty (2) Bases

Step 1: Remove the accent cover off of the bases by removing the thumb screws and pulling it off. Then bolt together the (2) Bases to the Trough assembly using the $\frac{1}{4}$ "-20 x 2-3/8" Bolt and $\frac{1}{4}$ "-20 Nuts. Next screw on the Short L-Brackets and the Long L-Brackets using the #10 x 3/4" Pan Head Screws evenly spaced. If the table is 48" wide, using the provided Cover Caps, cover the outside holes on the base.

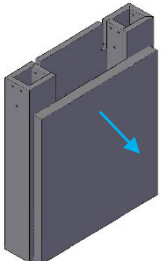

Base With Accent Cover

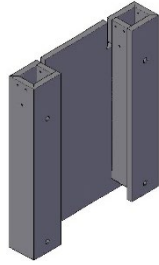

Base With Accent Cover Removed

Place Cover Caps here
on 48" wide tables

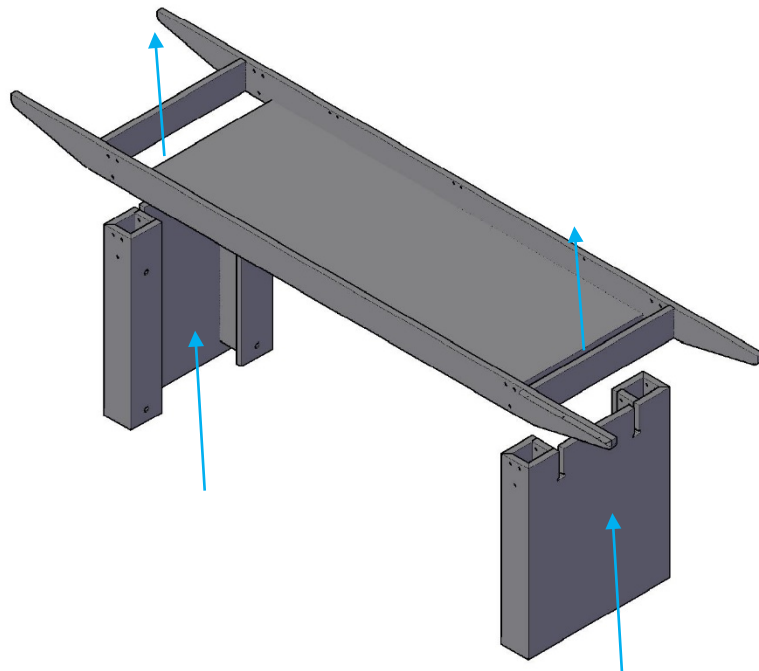
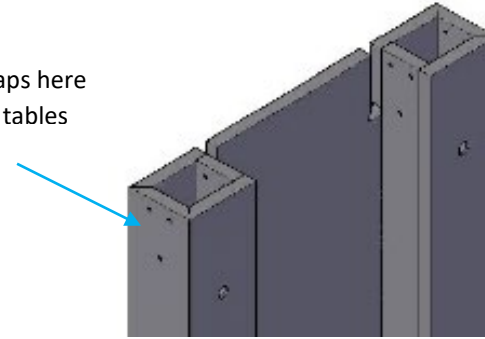

Bolt Trough Assembly together in (4) places

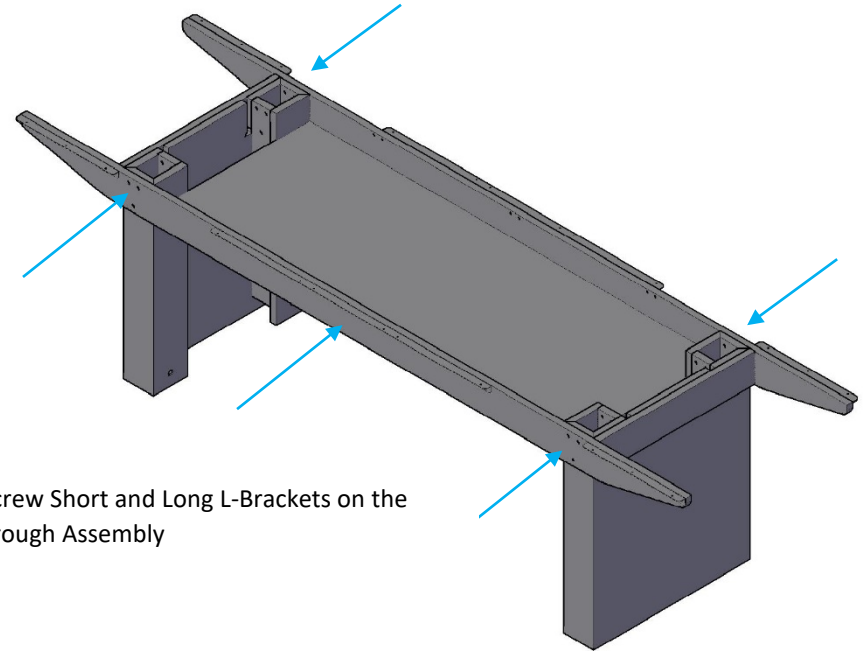

Screw Short and Long L-Brackets on the
Trough Assembly

Step 2: Place one short end on the end of the Trough Assembly and fasten it to the L-Brackets using #10 x 3/4" Pan Head Screws. Center the Top from left to right and align the Top flush with the outside of the base.

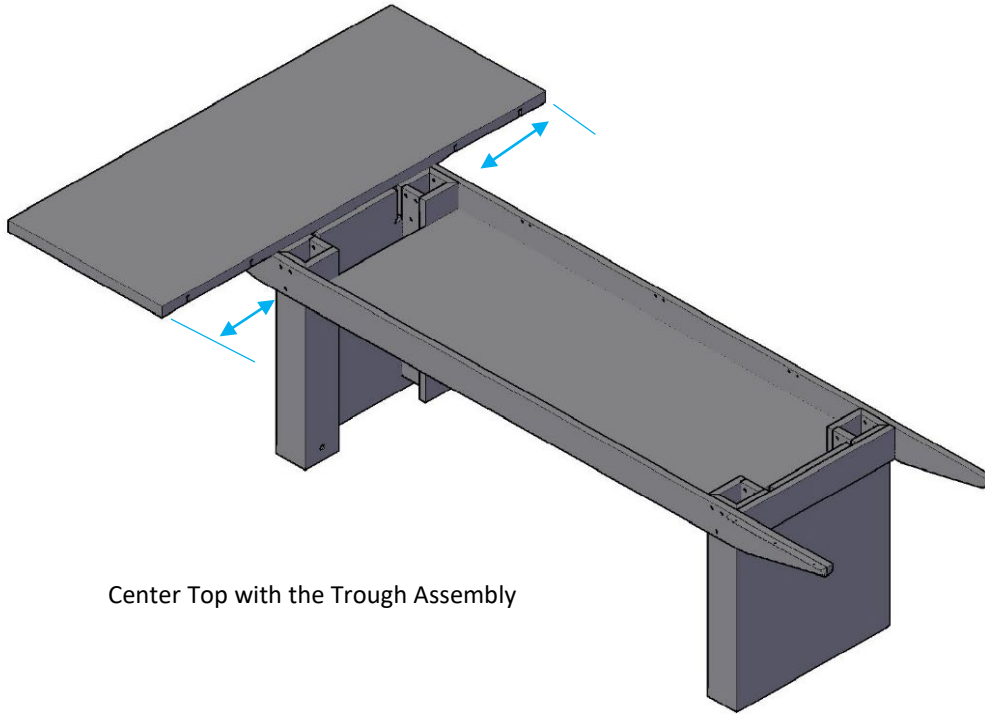

Center Top with the Trough Assembly

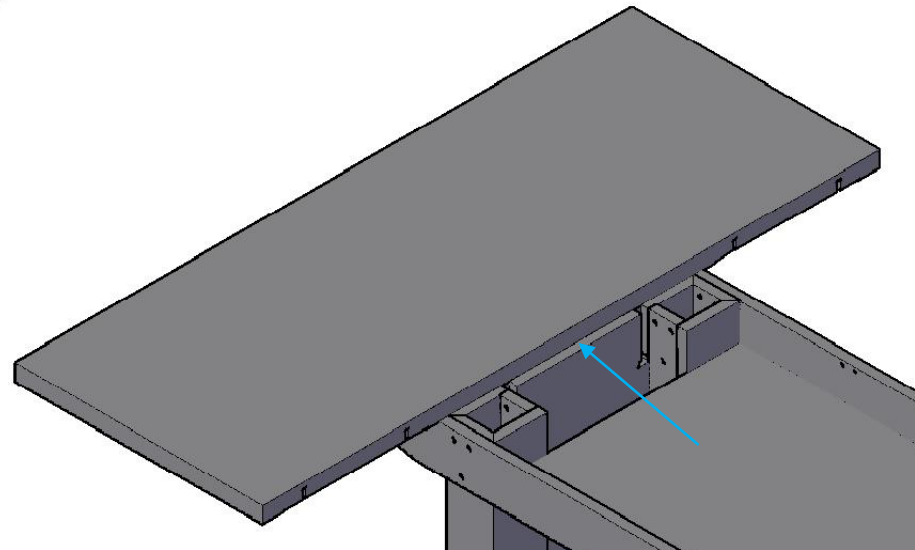

Make Top Flush with the outside of the base as shown.

Step 3: While keeping the outside and top surfaces flush, connect the remaining tops using the 10mm wrench and the provided Joints Bolts. Now, fasten the tops to the L-Brackets with the #10 x 3/4" Pan Head Screws. Next fasten the Joints Plates to the Tops using #10 x 3/4" Pan Head Screws.

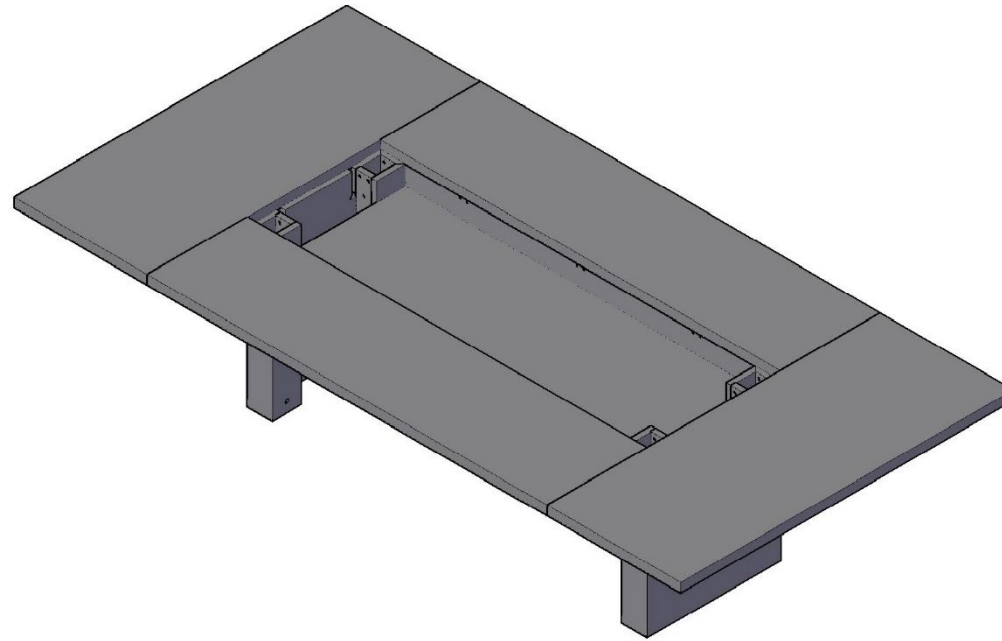

Place Joint Bolts in 1st then Fasten the Joints Plates

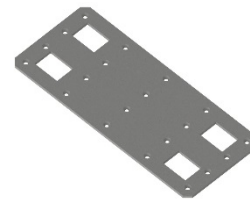

Jointer Plate

Step 4: Level the table using the 5mm Allen Wrench

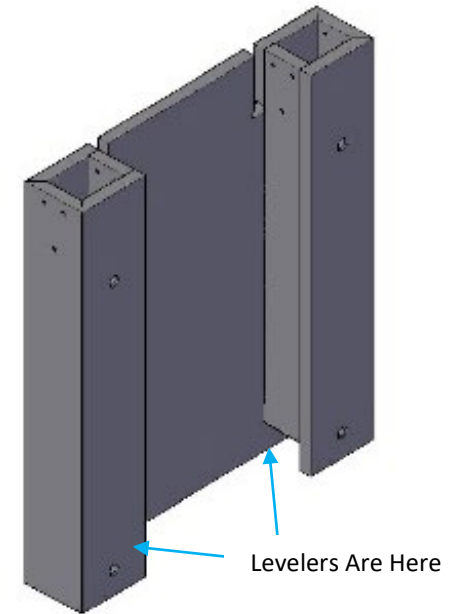
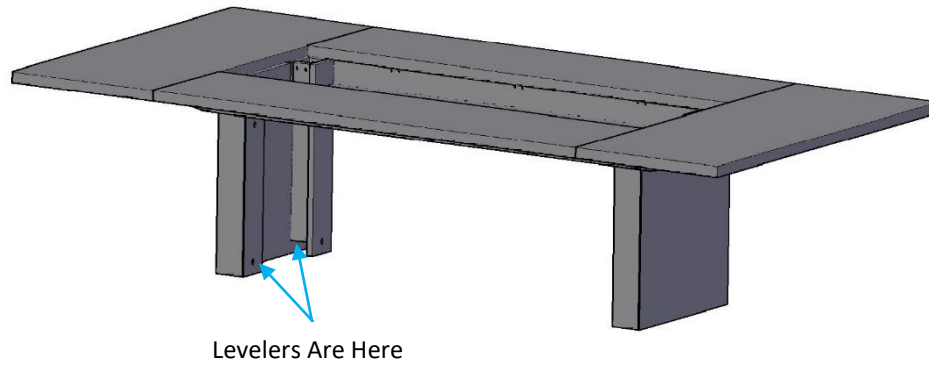

Step 5: Place the Accent in the table, adjust the height of the Accent Cover by using the adjustable levelers on the bottom of the Accent Cover

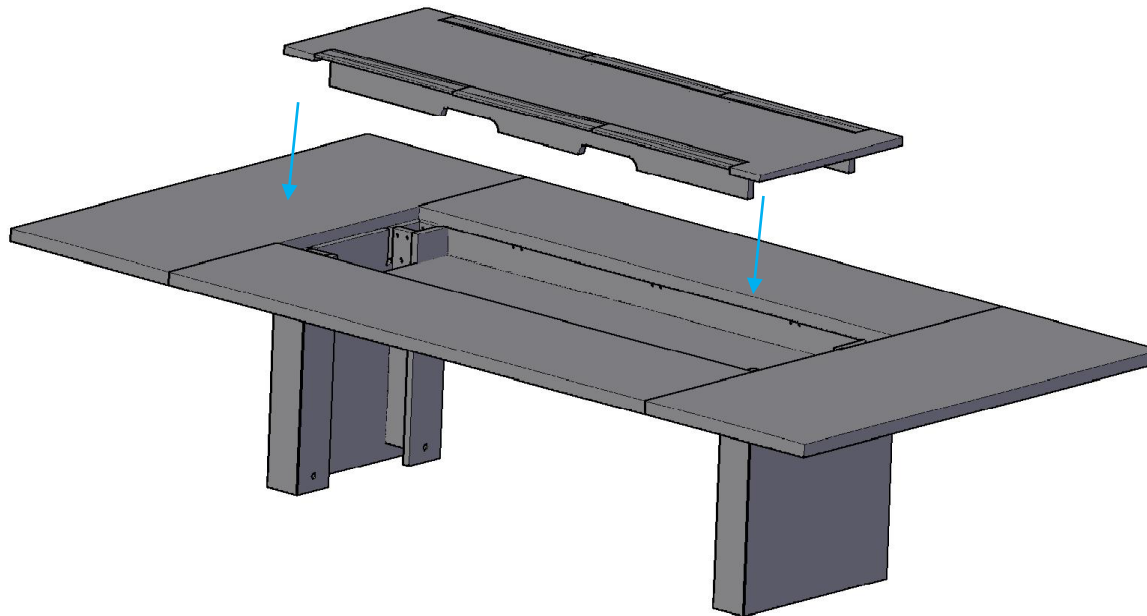

Step 6: Push on the Base Accent Panels and insert thumb screws from Step 1

Optional Step 10: Using a 1" Hole Saw Bit, drill a hole in the Accent Cover for the Optional Silver Polycom Grommet.

Bore Hole for Silver Polycom Grommet (Optional)

