

# Rectangle Base (01-2428RBV/ 01-2028RBV) | Indiana FURNITURE

## Attachment and Placement Instructions

Before attaching bases, please take appropriate precautions to protect the table top.

### Components:

- Table Leg
- 5/8" #8 Screw (Qty 24 per Base; 8 per Connector, 32 Per Stretcher Rail)
- Adjustable Glides (Qty 2 per base)
- L Brackets (Qty 6 per Base; 8 per Stretcher Rail)
- Connector Brackets (Qty 2 for 2 Pc Tops)
- Stretcher Rails (Set of 2 for 1 pc Top/2-4 set for 2 pc Top)

### Instructions

- 1 Insert adjustable glides into bottom of bases.
- 2 Attach angle brackets to the base at the pre-marked indentations. Keep top edge of bracket flush with top edge of base.
- 3 Attach L brackets to the stretcher rail per drawing. Picture only shows one side, repeat fastening brackets to other side. Total of (8) brackets per stretcher.

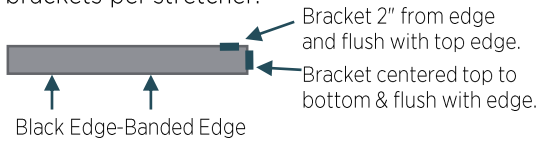

- 4 Fasten the stretchers to the slab base about 6" from each slab edge.
- 5 If it is a (2) piece top attach joint clamps to the table bottom, 2" from each edge. Level the top and then bring joint together and secure all adjusting screws. The (2) small set screws establish the final leveling
- 6 Measure and mark (15"/19") base/stretchers placement and overhang on bottom of table top.
- 7 Position bases/stretchers in place and attach to bottom of top with included screws.

Now, you're ready to turn table right side up, level table with adjustable glides.

For 2 pc top, fine tune adjust the connector brackets to level height between top pieces.

- 2 Attach angle brackets to the base at the pre-marked indentations.

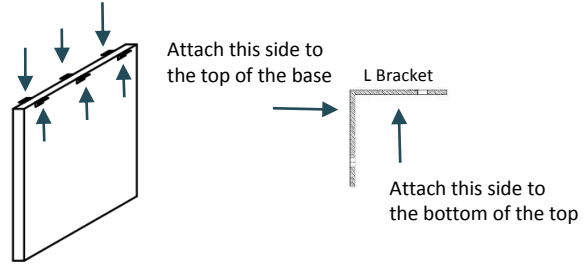

### 1 Pc Top

- 6 Measure and mark base placement and overhang
- 7 Position bases in places and attach to bottom of top.

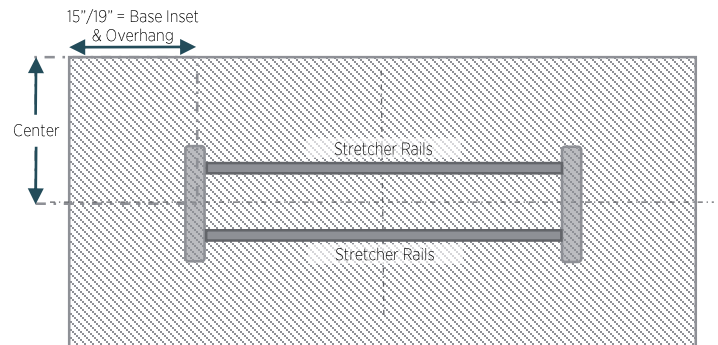

### 2 Pc Top

- 5 Attach connector brackets, level top and secure joint connection

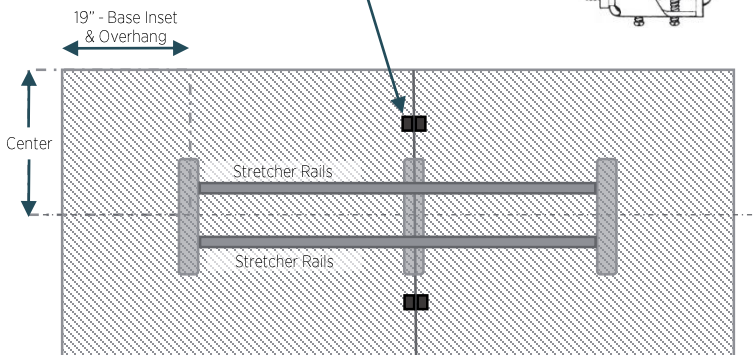

- 6 Measure and mark base placement and overhang
- 7 Position bases in places and attach to bottom of top.